

Applications of the Semantic Web for Healthcare

Poughkeepsie ACM Chapter

November 16 2015

John Sheehan
Rensselaer Polytechnic Institute



Understanding...
Consuming...
Building...
Improving Healthcare with...

...the Web of Data

Objectives

- The **Semantic Web** "stack" explained
- *Review* **Linked Data** principles & practices
- *Applications to Healthcare*
- *Research Projects at RPI*

Web Architecture

First Principles of The Web:

- A standard system for **identifying** resources
- Standard formats for **representing** resources
- A standard protocol for **exchanging** resources

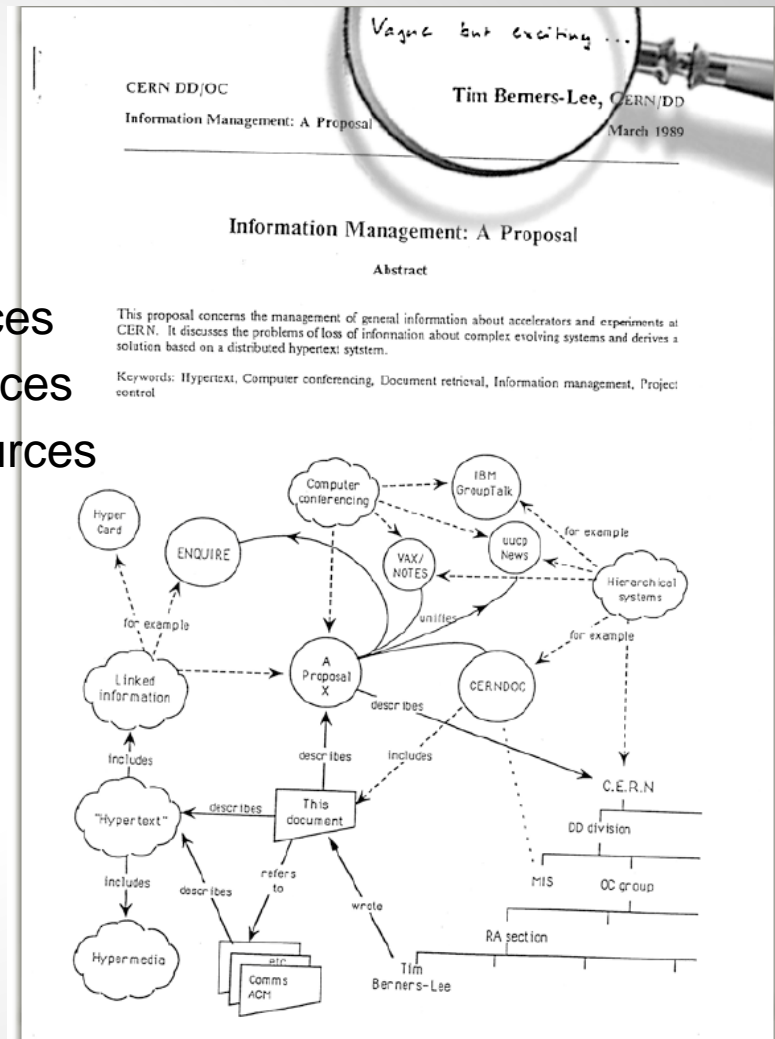

Web Architecture

First Principles of The Web:

- A standard system for **identifying** resources
- Standard formats for **representing** resources
- A standard protocol for **exchanging** resources

Relevant core standards:

- URLs: Uniform Resource Locators
- HTML: Hypertext Markup Language
- HTTP: Hypertext Transfer Protocol

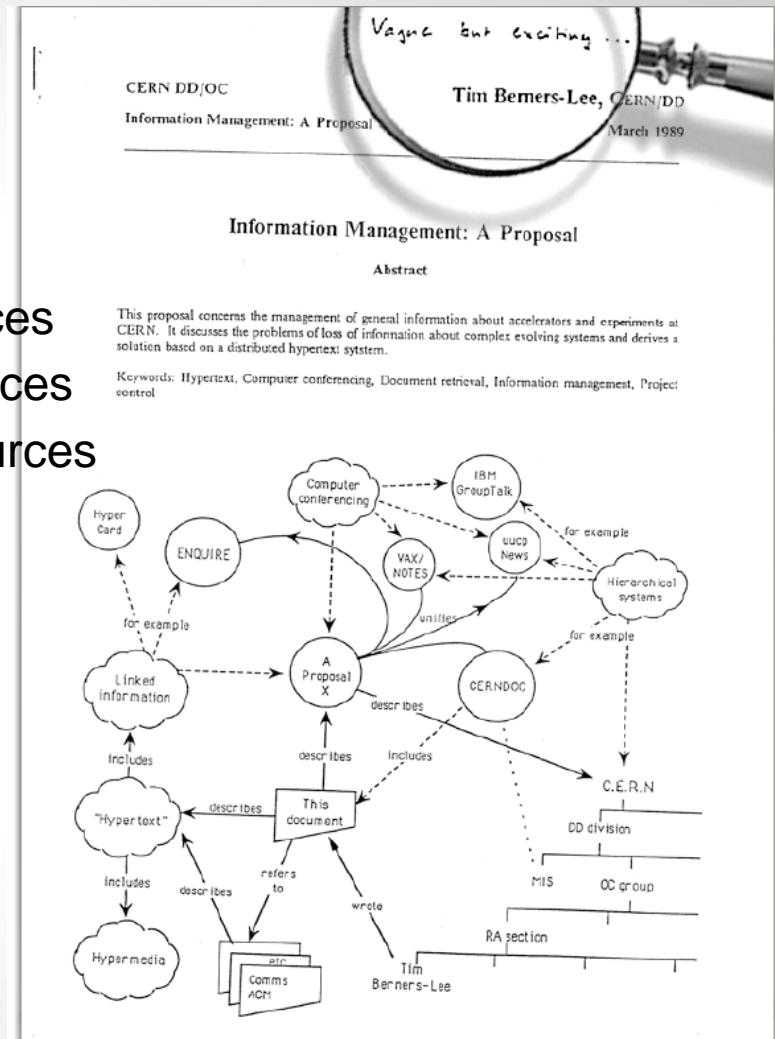

What's this "Semantic Web?"

...and where can I get one???

EXCLUSIVE: WARP DRIVE UNDERWATER • ARCTIC OIL VS. WILDLIFE

SCIENTIFIC AMERICAN

MAY 2011 \$4.99

Get the Idea? (TOMORROW'S WEB WILL)



PLUS:
Antibiotics' Dim Future
Rorschach: A Waste of Ink
The Oldest Stars

© 2011 Scientific American, Inc.

SCIENTIFIC AMERICAN™



Winner of the 2011 National Magazine Award for General Excellence

Search ScientificAmerican.com

- Subscribe
- News & Features
- Blogs
- Multimedia
- Education
- Citizen Science
- Topics

Home » Scientific American Magazine » May 2011

Feature Articles |

Tweet 5 Like 3

The Semantic Web [Preview]

A new form of Web content that is meaningful to computers will unleash a revolution of new possibilities.

By Tim Berners-Lee, James Hendler and Ora Lassila | May 1, 2011



are Email Print

Semantic Web?

Web of "meaning"

Web of Data

Linked Data

meaning
:
ideas
:
data

Linking ideas...

How does it work???

Semantic Web Building Blocks

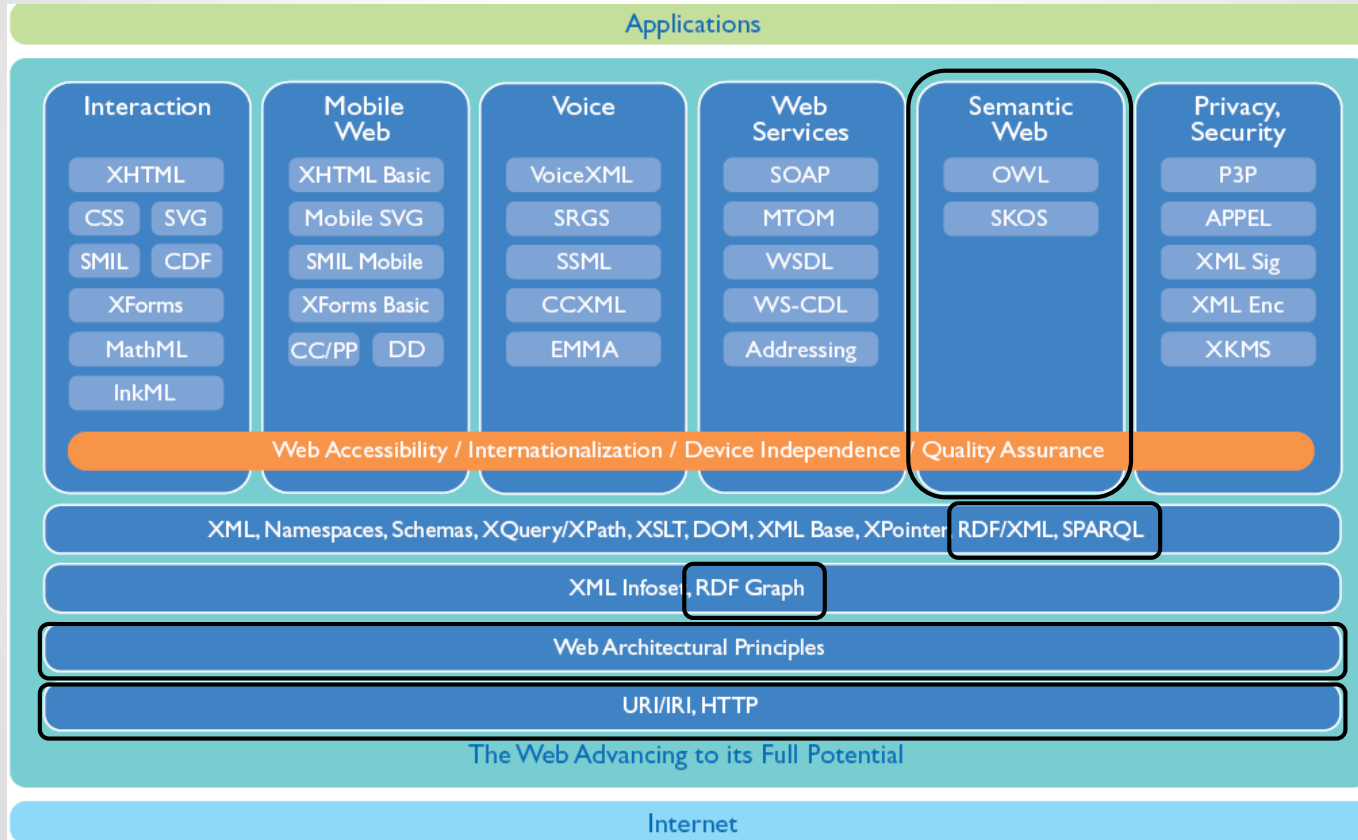

The Semantic Web Technology Stack (not a piece of cake...)

Most apps use only a subset of the stack

Querying allows fine-grained data access

Standardized information exchange is key

Formats are necessary, but not too important

The Semantic Web is based on the Web

Linked Data uses a small selection of technologies

LINKED DATA

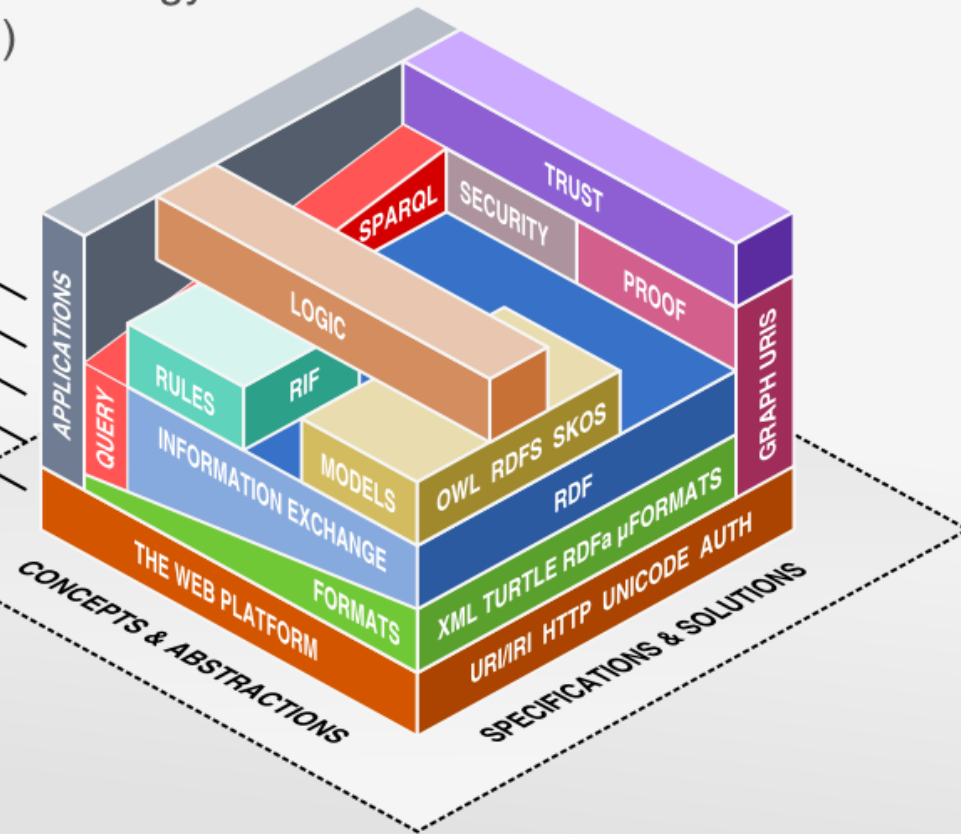

Identifying Web Resources

- A **global identification system** is essential...
 - ...to share information about resources
 - ...to reason about resources
 - ...to modify or exchange resources
- **Resources** are anything that can be linked to or spoken of
 - Documents, cat videos, people, ideas...
- Not all resources are *on* the Web
 - They might be referenced from the Web...
 - ...while not being retrievable from it
 - These are (so called) **information resources**

A **Uniform Resource Identifier (URI)** is used to identify the name of a resource. Enables interaction with representations of the resource over the Web

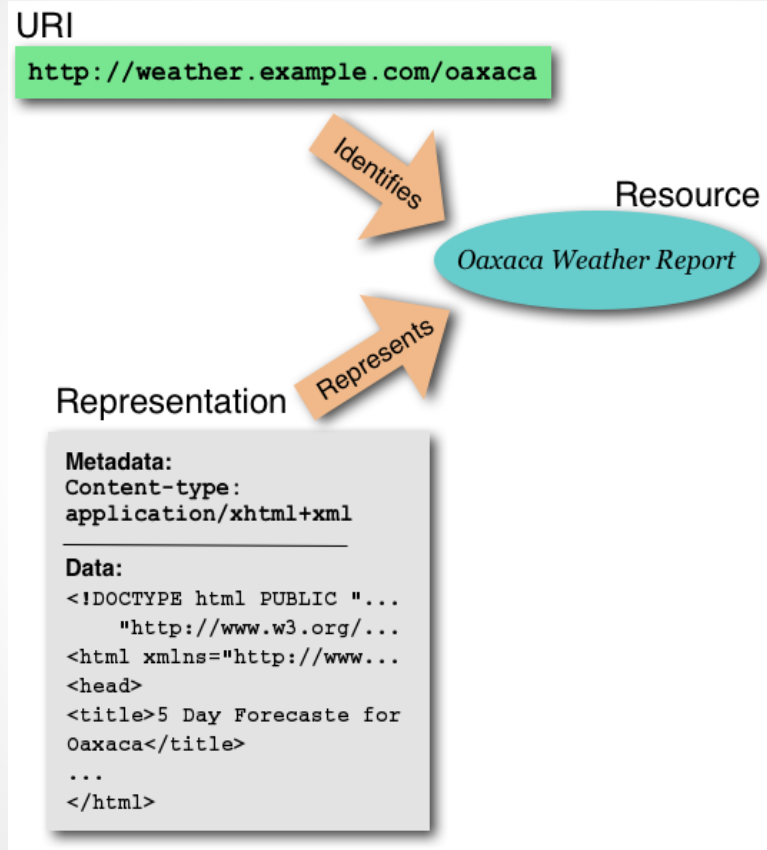

Identifying Web Resources

- A global standard is required; the **URI** is it
- Others systems are possible...
 - ...but added value of a **single global system** of identifiers is high
 - Enables linking, bookmarking and other functions across **heterogeneous applications**
- How are URIs used?
 - All resources have URIs associated with them
 - Each URI identifies a single resource in a context- independent manner
 - URIs act as names and (usually) addresses
 - In general URIs are "opaque"

Identifying Web Resources

- "URIs *identify* and URLs *locate*..."
 - ...and identify
- URLs are URIs aligned with protocols
 - URLs include the "access mechanism" or "network location"
e.g. `http://` or `ftp://`
 - How to "dereference" the URI and retrieve the thing
- URL examples
 - **`ftp://ftp.is.co.za/rfc/rfc1808.txt`**
 - **`http://www.ietf.org/rfc/rfc2396.txt`**
 - **`mailto:John.Doe@example.com`**
 - **`telnet://192.0.2.16:80/`**

Representing Resources

- Resources are manifest as digital files
 - More precisely: **serializations** that look like files...
- The Web recognizes a (growing) set of {file | serialization} formats
 - The original and workhorse is HTML...
 - ...but there are many others
- Retrievable resources on the web serve multiple purposes
 - Resources **encode** information and data
 - Resources **aggregate links** to other resources
- This is what makes The Web(tm) a "web..."

Resources (nodes) aggregate links to other resources to create a Web

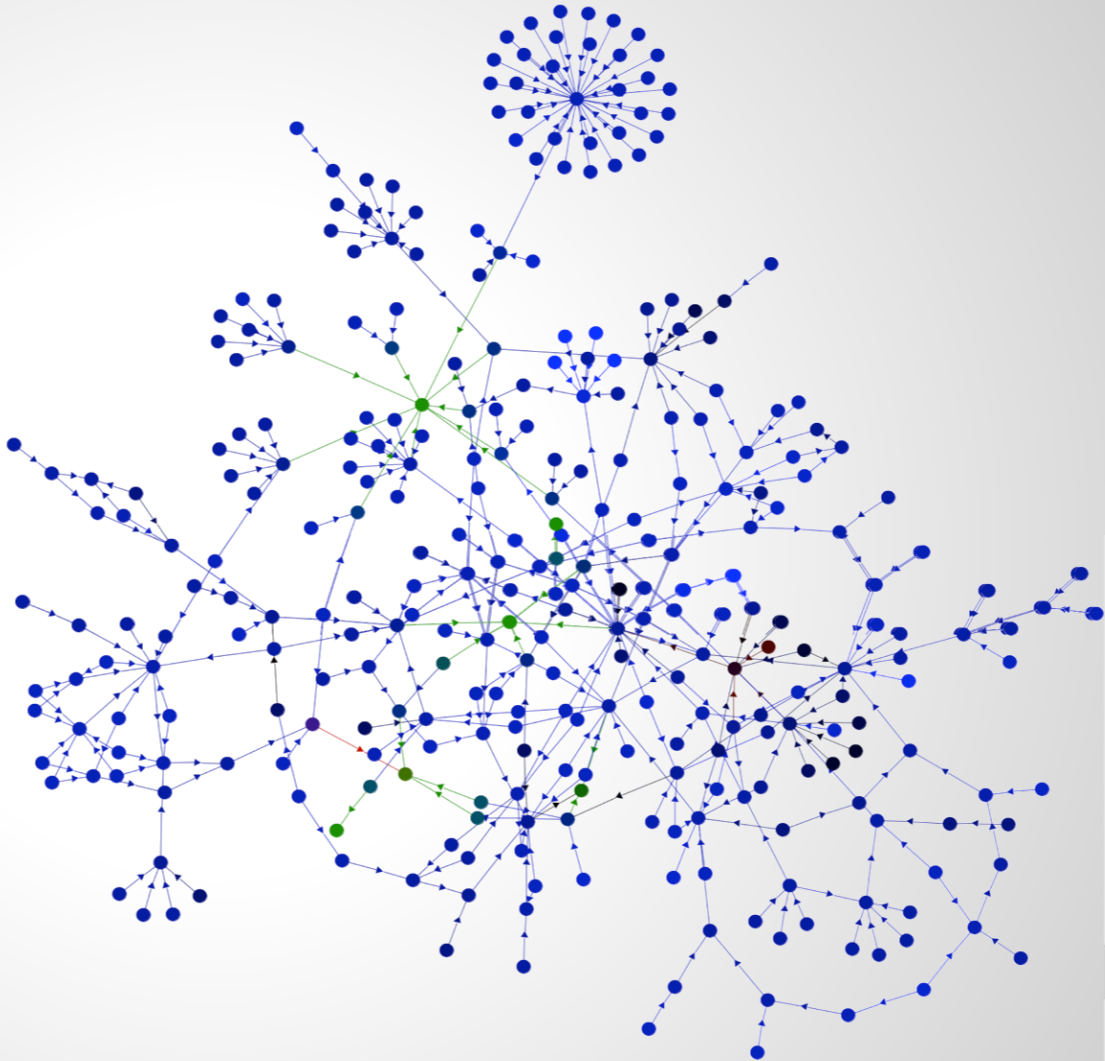
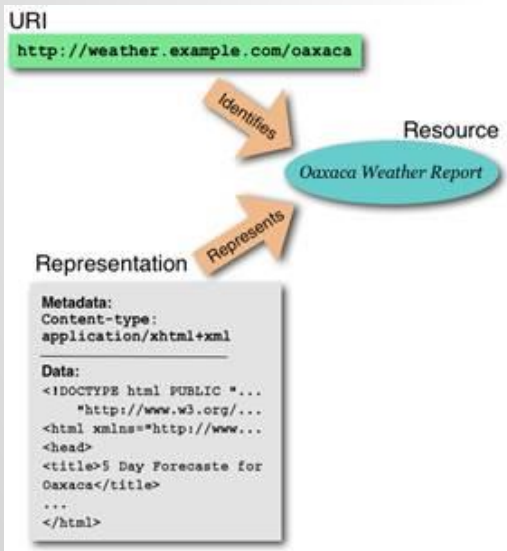

Retrieving Resources

- **Review:** URLs refer to retrievable resources
 - ie URIs that specify some **protocol** for retrieval
- The original and most common Web protocol is **HTTP**
- Specialized protocols are possible but resources may appear "off the grid..."
- More common case is HTTP w different formats...

RDF: Resource Description Framework

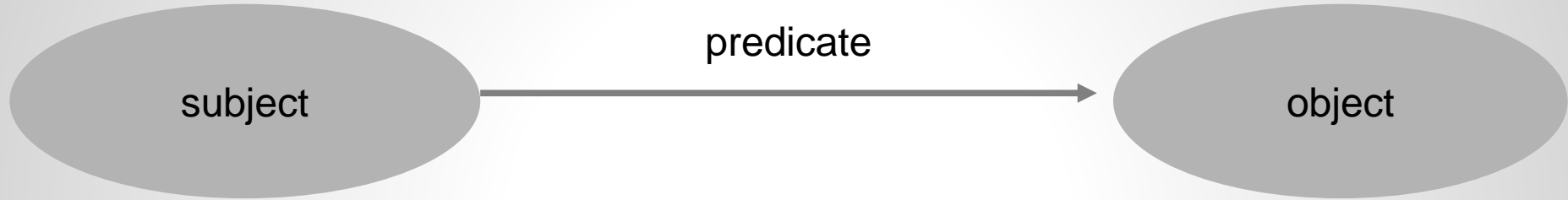

RDF: Resource Description Framework

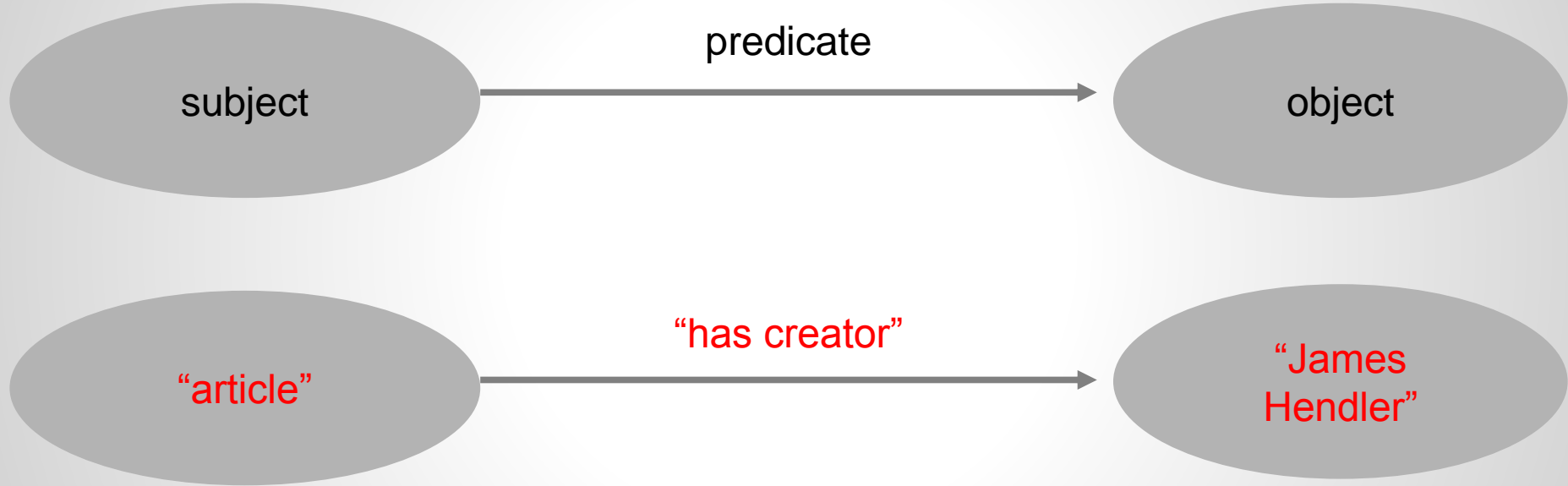

RDF: Resource Description Framework

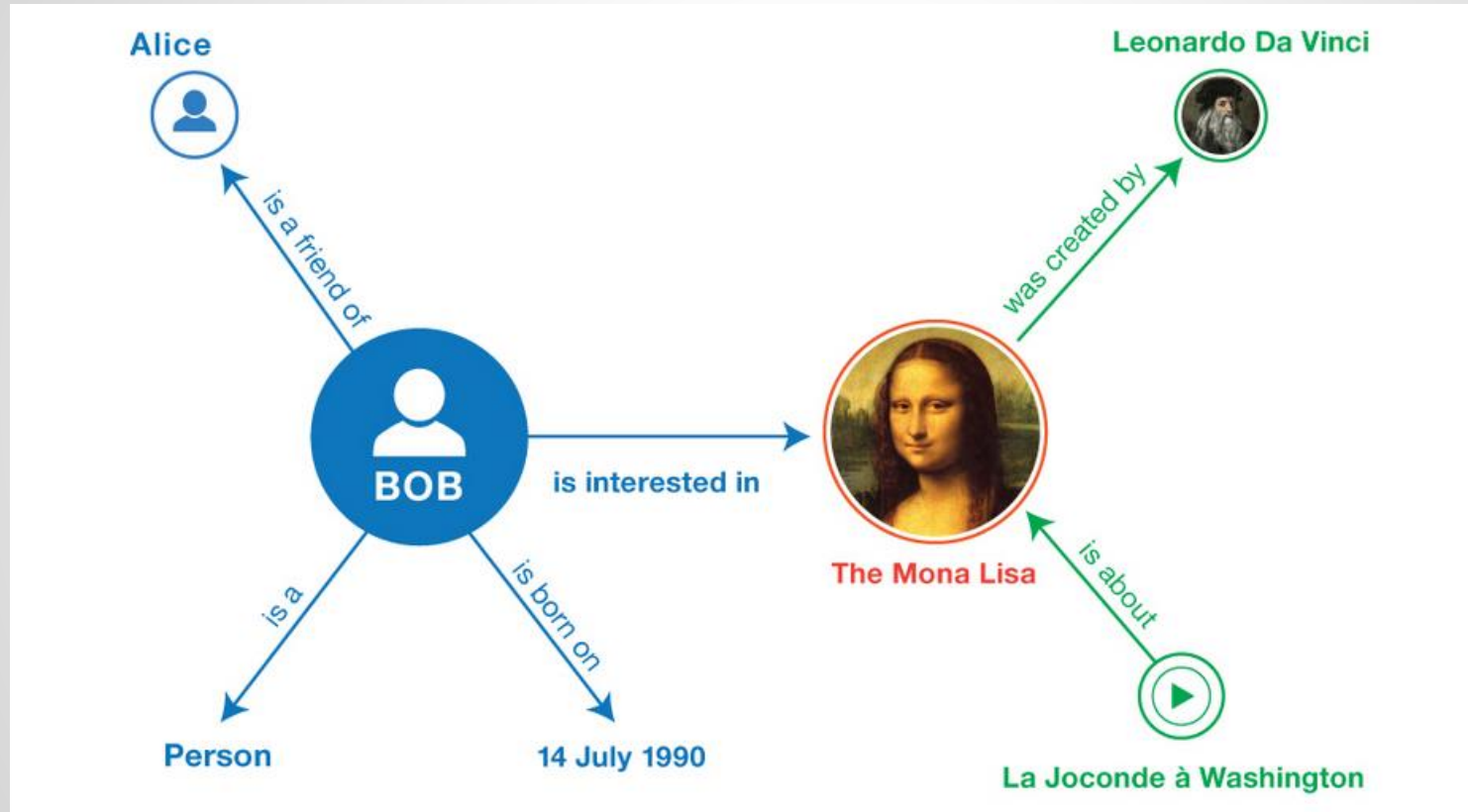

doi:10.1109/MC.2009.30

<http://purl.org/dc/elements/1.1/creator>

http://dbpedia.org/resource/James_Hendler

<http://purl.org/dc/elements/1.1/creator>
<http://dx.doi.org/10.1109/MC.2009.30>
http://dbpedia.org/resource/James_Hendler

doi:10.1109/MC.2009.30

Computer

Web 3.0 Emerging

January 2009 (vol. 42 no. 1)
pp. 111-113

Jim Hendler, Rensselaer Polytechnic Institute

DOI Bookmark: <http://doi.ieeecomputersociety.org/10.1109/MC.2009.30>

ABSTRACT

While Web 3.0 technologies are difficult to define precisely, the outline of emerging applications is clear over the past year.

ADDITIONAL INFORMATION

Index Terms:
Web 3.0, Web technologies, Semantic Web, linked data

Citation:
Jim Hendler, "Web 3.0 Emerging," *Computer*, vol. 42, no. 1, pp. 111-113, Jan. 2009, doi:10.1109/MC.2009.30

elements/1.1/creator

Term Name: creator	
URI:	http://purl.org/dc/elements/1.1/creator
Label:	Creator
Definition:	An entity primarily responsible for making the resource.
Comment:	Examples of a Creator include a person, an organization, or a service. Typically, the name of a Creator should be used to indicate the entity.



rg/resource/James_Hendle
r

- <http://purl.org/dc/elements/1.1/creator>
- <http://dx.doi.org/10.1109/MC.2009.30>
- http://dbpedia.org/resource/James_Hendler

We're missing something...

Check: URIs for names: S, P, O can be URIs

Check: HTTP URIs: all of our examples *are* resolvable

Now: "Return something useful" when we resolve URIs

Format: How do we *serialize* RDF?

Protocol: How do we *retrieve* RDF?

Let's go to the graph...

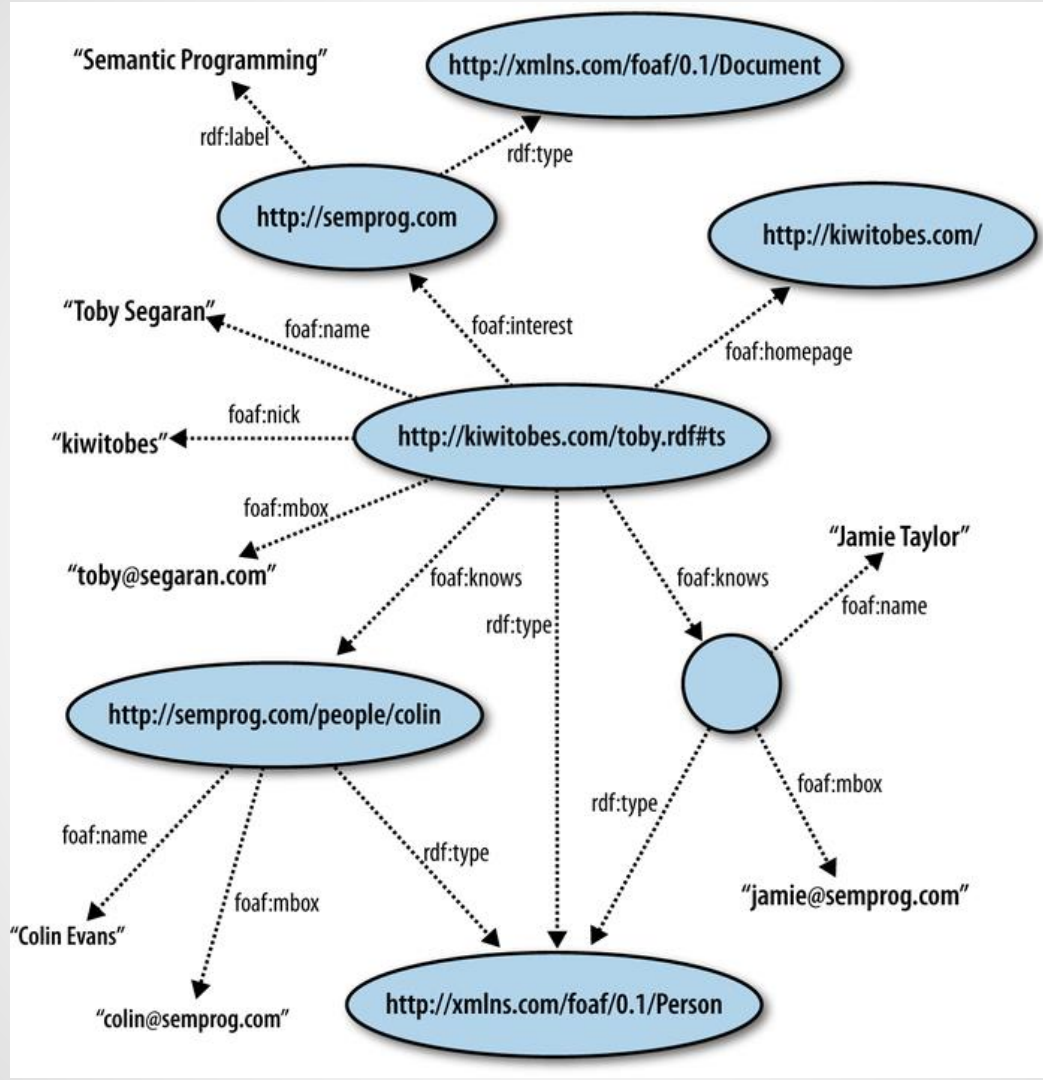

"Raw" Triples

Triples of the Data Model

Number	Subject	Predicate	Object
1	http://kiwitobes.com/toby.rdf#ts	http://www.w3.org/1999/02/22-rdf-syntax-ns#type	http://xmlns.com/foaf/0.1/Person
2	http://kiwitobes.com/toby.rdf#ts	http://xmlns.com/foaf/0.1/name	"Toby Segaran"
3	http://kiwitobes.com/toby.rdf#ts	http://xmlns.com/foaf/0.1/homepage	http://kiwitobes.com/
4	http://kiwitobes.com/toby.rdf#ts	http://xmlns.com/foaf/0.1/nick	"kiwitobes"
5	http://kiwitobes.com/toby.rdf#ts	http://xmlns.com/foaf/0.1/mbox	mailto:toby@segaran.com
6	http://semprog.com	http://www.w3.org/1999/02/22-rdf-syntax-ns#type	http://xmlns.com/foaf/0.1/Document
7	http://kiwitobes.com/toby.rdf#ts	http://xmlns.com/foaf/0.1/interest	http://semprog.com
8	http://semprog.com	http://www.w3.org/2000/01/rdf-schema#label	"Semantic Programming"
9	http://semprog.com/people/colin	http://www.w3.org/1999/02/22-rdf-syntax-ns#type	http://xmlns.com/foaf/0.1/Person
10	http://kiwitobes.com/toby.rdf#ts	http://xmlns.com/foaf/0.1/knows	http://semprog.com/people/colin
11	http://semprog.com/people/colin	http://xmlns.com/foaf/0.1/name	"Colin Evans"
12	http://semprog.com/people/colin	http://xmlns.com/foaf/0.1/mbox	mailto:colin@semprog.com
13	genid:A708592	http://www.w3.org/1999/02/22-rdf-syntax-ns#type	http://xmlns.com/foaf/0.1/Person
14	http://kiwitobes.com/toby.rdf#ts	http://xmlns.com/foaf/0.1/knows	genid:A708592
15	genid:A708592	http://xmlns.com/foaf/0.1/name	"Jamie Taylor"
16	genid:A708592	http://xmlns.com/foaf/0.1/mbox	mailto:jamie@semprog.com

Via the W3C RDF VCalidator Service:

<http://www.w3.org/RDF/Validator/>

N-Triples...

```
<http://kiwitobes.com/toby.rdf#ts> <http://xmlns.com/foaf/0.1/homepage> <http://kiwitobes.com/>.
<http://kiwitobes.com/toby.rdf#ts> <http://xmlns.com/foaf/0.1/nick> "kiwitobes".
<http://kiwitobes.com/toby.rdf#ts> <http://xmlns.com/foaf/0.1/name> "Toby Segaran".
<http://kiwitobes.com/toby.rdf#ts> <http://xmlns.com/foaf/0.1/mbox> <mailto:toby@segaran.com>.
<http://kiwitobes.com/toby.rdf#ts> <http://xmlns.com/foaf/0.1/interest> <http://semprog.com>.
<http://kiwitobes.com/toby.rdf#ts> <http://www.w3.org/1999/02/22-rdf-syntax-ns#type>
<http://xmlns.com/foaf/0.1/Person>.

<http://kiwitobes.com/toby.rdf#ts> <http://xmlns.com/foaf/0.1/knows> _:jamie .
<http://kiwitobes.com/toby.rdf#ts> <http://xmlns.com/foaf/0.1/knows> <http://semprog.com/people/colin>.

_:jamie <http://xmlns.com/foaf/0.1/name> "Jamie Taylor".
_:jamie <http://xmlns.com/foaf/0.1/mbox> <mailto:jamie@semprog.com>.
_:jamie <http://www.w3.org/1999/02/22-rdf-syntax-ns#type> <http://xmlns.com/foaf/0.1/Person>.

<http://semprog.com/people/colin> <http://xmlns.com/foaf/0.1/name> "Colin Evans".
<http://semprog.com/people/colin> <http://xmlns.com/foaf/0.1/mbox> <mailto:colin@semprog.com>.
<http://semprog.com/people/colin> <http://www.w3.org/1999/02/22-rdf-syntax-ns#type>
<http://xmlns.com/foaf/0.1/Person>.

<http://semprog.com> <http://www.w3.org/2000/01/rdf-schema#label> "Semantic Programming".
<http://semprog.com> <http://www.w3.org/1999/02/22-rdf-syntax-ns#type> <http://xmlns.com/foaf/0.1/Document>.
```

N3...

```
@prefix foaf: <http://xmlns.com/foaf/0.1/>.
@prefix rdf: <http://www.w3.org/1999/02/22-rdf-syntax-ns#>.
@prefix rdfs: <http://www.w3.org/2000/01/rdf-schema#>.
@prefix semperp: <http://semprog.com/people/>.
@prefix tobex: <http://kiwitobes.com/toby.rdf#>.
```

tobex:ts a foaf:Person;

```
foaf:homepage <http://kiwitobes.com/>;
foaf:interest <http://semprog.com>;
foaf:knows semperp:colin,
  [ a foaf:Person;
    foaf:mbox <mailto:jamie@semprog.com>;
    foaf:name "Jamie Taylor";
  foaf:mbox <mailto:toby@segaran.com>;
foaf:name "Toby Segaran";
foaf:nick "kiwitobes".
```

```
<http://semprog.com> a foaf:Document;
  rdfs:label "Semantic Programming".
```

```
semperp:colin a foaf:Person;
  foaf:mbox <mailto:colin@semprog.com>;
  foaf:name "Colin Evans".
```

RDFa...

```
:  
<div xmlns:foaf="http://xmlns.com/foaf/0.1/" about="http://kiwitobes.com/toby.rdf#ts" typeof="foaf:Person">  
  
  Name: <span property="foaf:name">Toby Segaran</span><br/>  
  Nickname: <span property="foaf:nick">kiwitobes</span><br/>  
  Interests: <a rel="foaf:interest" href="http://semprog.org">  
    <span property="rdfs:label">Semantic Programming</span></a>  
  Homepage: <a rel="foaf:homepage" href="http://kiwkitobes.com/">KiwiTobes</a><p/>  
  
  Friends:<br/>  
  <ul rel="foaf:knows">  
    <li about="http://semprog.com/people/colin"                                typeof="foaf:Person"  
property="foaf:name">Colin Evans</li>  
  
    <li typeof="foaf:Person">  
      <span property="foaf:name">Jamie Taylor</span><br/>  
      Email: <a rel="foaf:mbox" href="mailto:jamie@semprog.com">  
        jamie@semprog.com</a><br/>  
    </li>  
  
  </ul>  
</div>  
:
```

RDF/XML...

```
<rdf:RDF
  xmlns:foaf='http://xmlns.com/foaf/0.1/'
  xmlns:rdf='http://www.w3.org/1999/02/22-rdf-syntax-ns#'
  xmlns:rdfs='http://www.w3.org/2000/01/rdf-schema#'>

  <foaf:Person rdf:about="http://kiwitobes.com/toby.rdf#ts">
    <foaf:name>Toby Segaran</foaf:name>
    <foaf:homepage rdf:resource="http://kiwitobes.com/">
    <foaf:nick>kiwitobes</foaf:nick>
    <foaf:mbox rdf:resource="mailto:toby@segaran.com"/>

    <foaf:interest>
      <foaf:Document rdf:about="http://semprog.com">
        <rdfs:label>Semantic Programming</rdfs:label>
      </foaf:Document>
    </foaf:interest>

    <foaf:knows>
      <foaf:Person rdf:about="http://semprog.com/people/colin">
        <foaf:name>Colin Evans</foaf:name>
        <foaf:mbox rdf:resource="mailto:colin@semprog.com"/>
      </foaf:Person>

    </foaf:knows>
    <foaf:knows>
      <foaf:Person>
        <foaf:name>Jamie Taylor</foaf:name>
        <foaf:mbox rdf:resource="mailto:jamie@semprog.com"/>
      </foaf:Person>
    </foaf:knows>

  </foaf:Person>
</rdf:RDF>
```

JSON-LD...

```
{
  "@graph": [
    {
      "@id": "http://kiwitobes.com/toby.rdf#ts",
      "@type": "http://xmlns.com/foaf/0.1/Person",
      "http://xmlns.com/foaf/0.1/homepage": {
        "@id": "http://kiwitobes.com/"
      },
      "http://xmlns.com/foaf/0.1/interest": {
        "@id": "http://semprog.com"
      },
      "http://xmlns.com/foaf/0.1/knows": [
        {
          "@type": "http://xmlns.com/foaf/0.1/Person",
          "http://xmlns.com/foaf/0.1/mbox": {
            "@id": "mailto:jamie@semprog.com"
          },
          "http://xmlns.com/foaf/0.1/name": "Jamie Taylor"
        },
        {
          "@id": "http://semprog.com/people/colin"
        }
      ],
      "http://xmlns.com/foaf/0.1/mbox": {
        "@id": "mailto:toby@segaran.com"
      },
      "http://xmlns.com/foaf/0.1/name": "Toby Segaran",
      "http://xmlns.com/foaf/0.1/nick": "kiwitobes"
    },
    {
      "@id": "http://semprog.com/people/colin",
      "@type": "http://xmlns.com/foaf/0.1/Person",
      "http://xmlns.com/foaf/0.1/mbox": {
        "@id": "mailto:colin@semprog.com"
      },
      "http://xmlns.com/foaf/0.1/name": "Colin Evans"
    },
    {
      "@id": "http://semprog.com",
      "@type": "http://xmlns.com/foaf/0.1/Document",
      "http://www.w3.org/2000/01/rdf-schema#label": "Semantic Programming"
    }
  ]
}
```

RDF/JSON...

```
{
  "http://kiwitobes.com/toby.rdf#ts": {
    "http://xmlns.com/foaf/0.1/nick": [
      {
        "type": "literal",
        "value": "kiwitobes"
      }
    ],
    "http://www.w3.org/1999/02/22-rdf-syntax-ns#type": [
      {
        "type": "uri",
        "value": "http://xmlns.com/foaf/0.1/Person"
      }
    ],
    "http://xmlns.com/foaf/0.1/interest": [
      {
        "type": "uri",
        "value": "http://semprog.com"
      }
    ],
    "http://xmlns.com/foaf/0.1/knows": [
      {
        "type": "uri",
        "value": "http://semprog.com/people/colin"
      },
      {
        "type": "bnode",
        "value": "_:N40b366148cfc4c48a80f4e15acbd2858"
      }
    ],
    "http://xmlns.com/foaf/0.1/mbox": [
      {
        "type": "uri",
        "value": "mailto:toby@segaran.com"
      }
    ]
  },
  "http://xmlns.com/foaf/0.1/homepage": [
    {
      "type": "uri",
      "value": "http://kiwitobes.com/"
    }
  ],
  "http://xmlns.com/foaf/0.1/name": [
    {
      "type": "literal",
      "value": "Toby Segaran"
    }
  ],
  "http://semprog.com/people/colin": {
    "http://xmlns.com/foaf/0.1/mbox": [
      {
        "type": "uri",
        "value": "mailto:colin@semprog.com"
      }
    ],
    "http://xmlns.com/foaf/0.1/name": [
      {
        "type": "literal",
        "value": "Colin Evans"
      }
    ]
  },
  "http://www.w3.org/1999/02/22-rdf-syntax-ns#type": [
    {
      "type": "uri",
      "value": "http://xmlns.com/foaf/0.1/Person"
    }
  ],
  "_:N40b366148cfc4c48a80f4e15acbd2858": {
    "http://xmlns.com/foaf/0.1/mbox": [
      {
        "type": "uri",
        "value": "mailto:jamie@semprog.com"
      }
    ]
  },
  "http://xmlns.com/foaf/0.1/name": [
    {
      "type": "literal",
      "value": "Jamie Taylor"
    }
  ],
  "http://www.w3.org/1999/02/22-rdf-syntax-ns#type": [
    {
      "type": "uri",
      "value": "http://xmlns.com/foaf/0.1/Person"
    }
  ],
  "http://semprog.com": {
    "http://www.w3.org/1999/02/22-rdf-syntax-ns#type": [
      {
        "type": "uri",
        "value": "http://xmlns.com/foaf/0.1/Document"
      }
    ],
    "http://www.w3.org/2000/01/rdf-schema#label": [
      {
        "type": "literal",
        "value": "Semantic Programming"
      }
    ]
  }
}
```

RDF Serialization: Summary

N-Triples: Verbose, "pedagogical"

N3: Concise, in common use;

RDFa: Commonly used for embedded RDF

RDF/XML: Some use in government & "enterprise"

JSON-LD: Fast-rising LD standard

RDF/JSON: Older convention for LD applications

Things we still haven't discussed...

How to **retrieve** this "linked data" of which I speak

How (and where?) to query RDF "graphs"

How to use LD in applications

How to create visualizations & "mashups"

Also:

How to create and publish linked data...

Consuming Linked Data

Querying RDF using SPARQL

Endpoints and triple stores

Mashing data in the query

Mashing data in the application

URIs, HTTP, many formats...

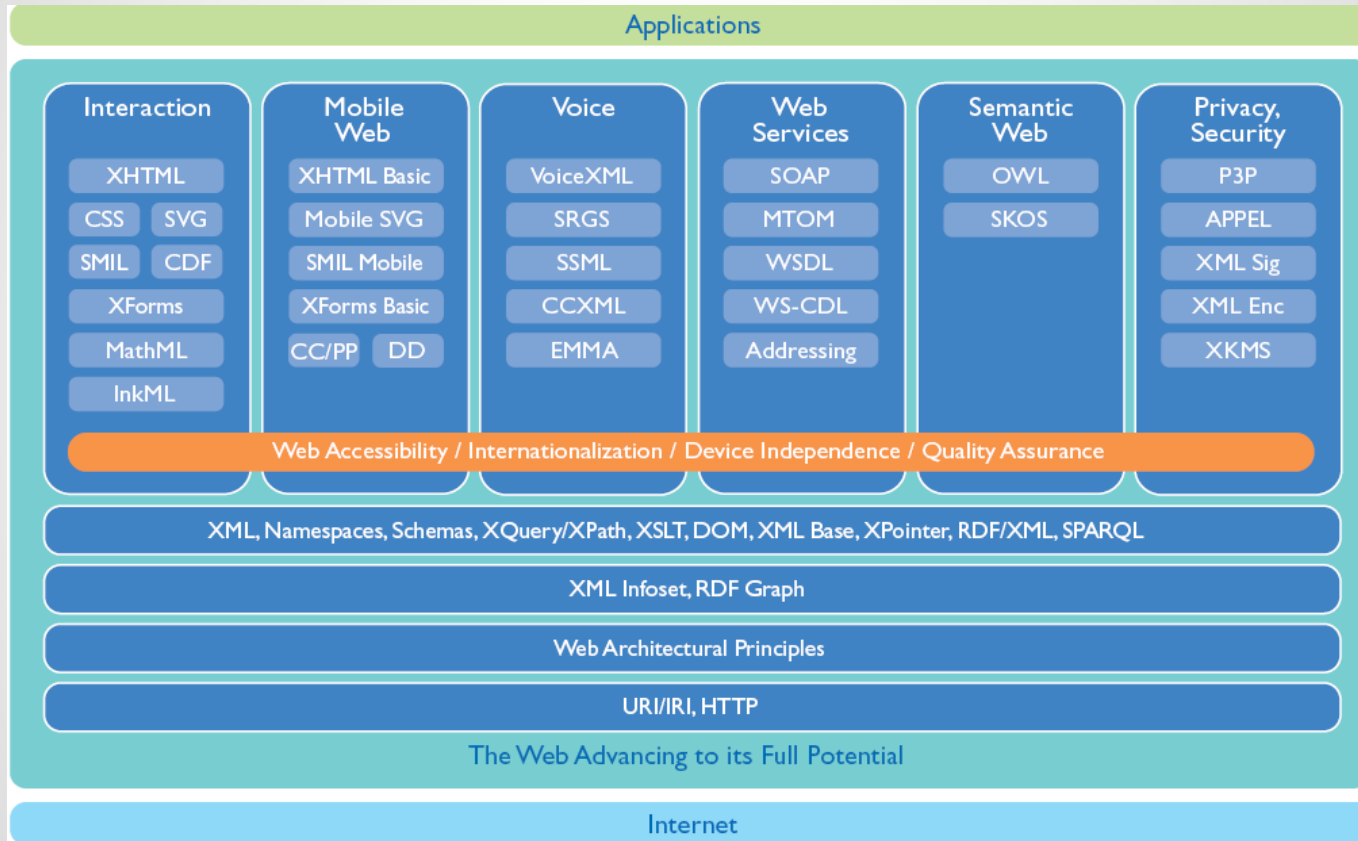

Principles for creating a healthy Web

Use **URIs** as *names* for things

Use **HTTP URIs** so people can *look up* those names

When someone *looks up* a URI, return useful information

use standard representation formats to express it

Include links to other URIs, so consumers can discover more things

By "consumers" we mean *people* or *applications*

Why is linking important???

Implications of a well-connected Web

Links to other nodes
are a "vote" of quality
and/or relevance

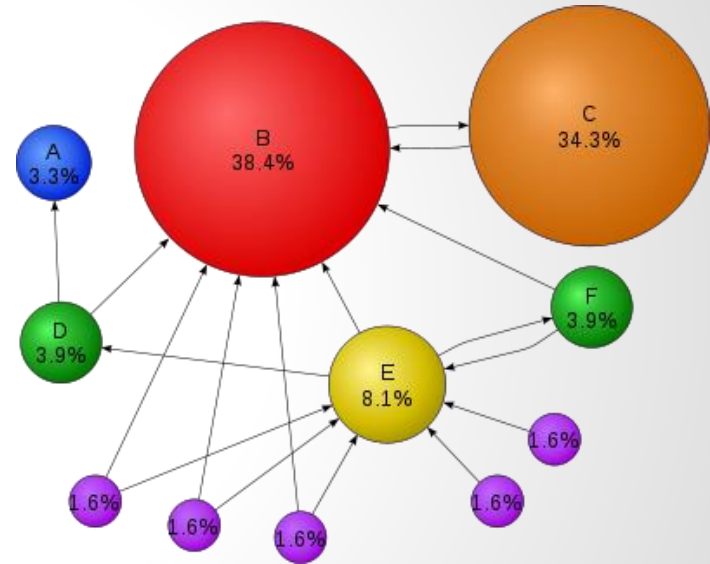

Google PageRank

Perspective: *Consuming* the Web of Data

1. From the *Web of Documents* to the *Web of Data*
2. *Linked Data*: Building Blocks of the Web (of Data)
3. *Mashups*: Consuming Linked Data

Open Linked Data Gains Momentum

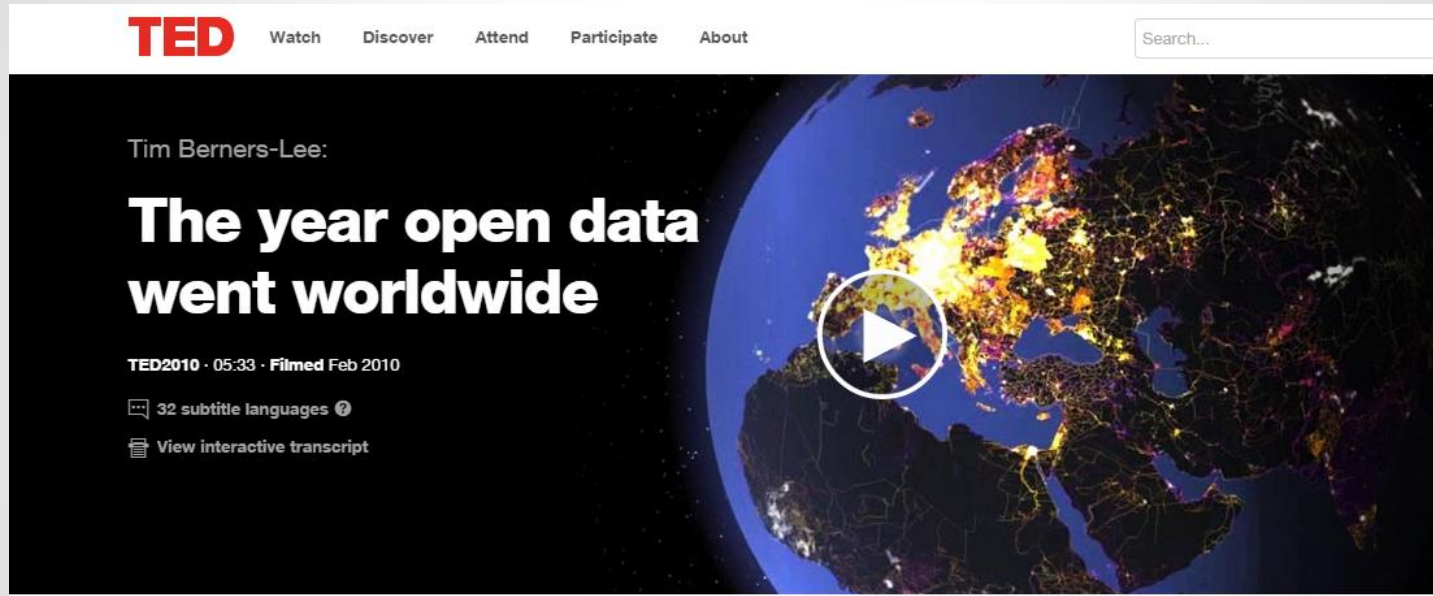

The image shows a screenshot of a TED talk video player. At the top left is the TED logo in red. To its right are navigation links: Watch, Discover, Attend, Participate, and About. On the top right is a search bar with the text "Search...". The main content area features a dark background with a glowing network map of the world. On the left side of this area, the text reads: "Tim Berners-Lee:", "The year open data went worldwide", "TED2010 · 05:33 · Filmed Feb 2010", "32 subtitle languages", and "View interactive transcript". A white play button icon is centered over the network map.

[Tim Berners Lee's TED talk on Linked Data](#)

Learning

SPARQL



W3C Recommendation

O'REILLY®

Bob DuCh

SPARQL: pattern matching over RDF graphs



SPARQL Query Language for RDF

W3C Recommendation 15 January 2008

This version:

<http://www.w3.org/TR/2008/REC-rdf-sparql-query-20080115/>

Latest version:

<http://www.w3.org/TR/rdf-sparql-query/>

Previous version:

<http://www.w3.org/TR/2007/PR-rdf-sparql-query-20071112/>

Editors:

Eric Prud'hommeaux, W3C <eric@w3.org>

Andy Seaborne, Hewlett-Packard Laboratories, Bristol <andy.seaborne@hp.com>

Improving the Bart blackboard query.

Since I [first wrote on](#) sending DBpedia SPARQL queries about Bart's blackboard messages at the start of Simpsons episodes, I've learned a lot more about SPARQL (reading [the spec](#) helped) and I wanted to walk through some of the things I've learned by expanding on and refining my original query.

I had finished that entry by wondering how to list

Bart's blackboard entries for all episodes instead of for just one season. Vaclav

Synacek [showed me one way](#), and I recently realized that there's a much simpler way—maybe too simple (all queries shown assume the namespace declarations

shown on the [SNORQL interface form](#) for sending SPARQL queries to DBpedia):

```
SELECT ?blackboard WHERE {  
  ?s dbpedia2:blackboard ?blackboard.  
}
```

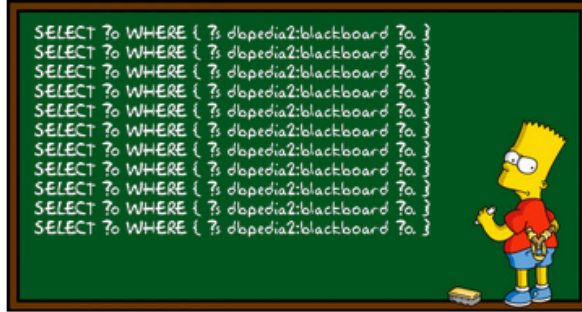

<http://bit.ly/RumkhW>

?s

dbpedia2:blackboard

?blackboard

Improving the Bart blackboard query.

Since I [first wrote on](#) sending DBpedia SPARQL queries about Bart's blackboard messages at the start of Simpsons episodes, I've learned a lot more about SPARQL (reading [the spec](#) helped) and I wanted to walk through some of the things I've learned by expanding on and refining my original query.

I had finished that entry by

wondering how to list

Bart's blackboard entries

for all episodes instead of

for just one season. Vaclav

Synace [showed me one](#)

[way](#), and I recently realiz

that there's a much simpl

way—maybe too simple

(all queries shown assum

the namespace declarati

shown on the [SNORQL i](#)

```
SELECT ?blackboard {
  ?s dbpedia2:blackboard
}
```

<http://bit.ly/RumkhW>

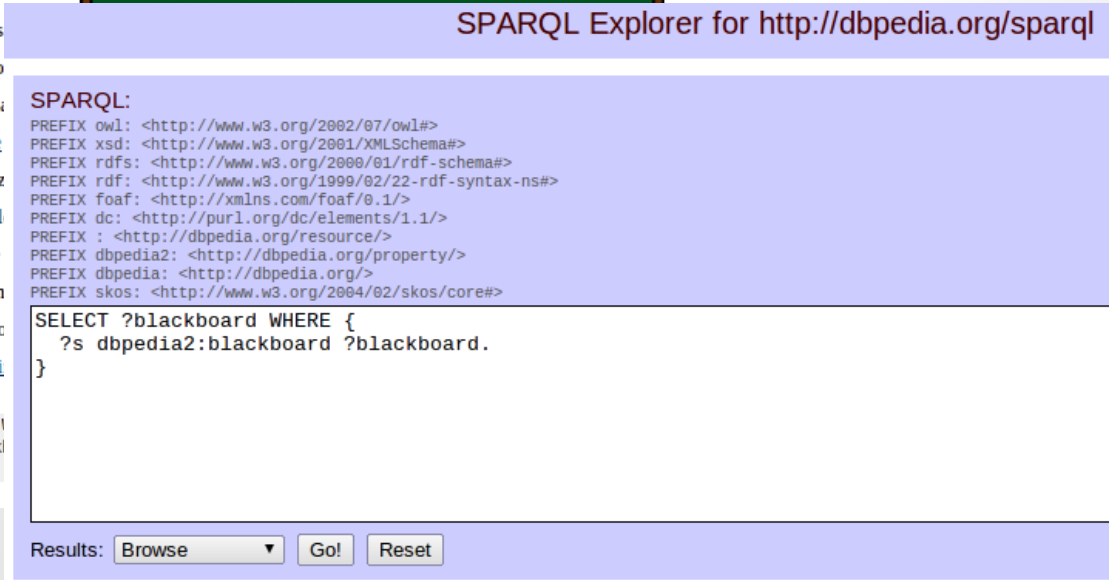

SPARQL Explorer for <http://dbpedia.org/sparql>

SPARQL:

```
PREFIX owl: <http://www.w3.org/2002/07/owl#>
PREFIX xsd: <http://www.w3.org/2001/XMLSchema#>
PREFIX rdfs: <http://www.w3.org/2000/01/rdf-schema#>
PREFIX rdf: <http://www.w3.org/1999/02/22-rdf-syntax-ns#>
PREFIX foaf: <http://xmlns.com/foaf/0.1/>
PREFIX dc: <http://purl.org/dc/elements/1.1/>
PREFIX : <http://dbpedia.org/resource/>
PREFIX dbpedia2: <http://dbpedia.org/property/>
PREFIX dbpedia: <http://dbpedia.org/>
PREFIX skos: <http://www.w3.org/2004/02/skos/core#>
```

```
SELECT ?blackboard WHERE {
  ?s dbpedia2:blackboard ?blackboard.
}
```

Results:



Improving the Bart blackboard query.

Since I [first wrote on](#) sending DBpedia SPARQL queries about Bart's blackboard messages at the start of Simpsons episodes, I've learned a lot more about SPARQL (reading [the spec](#) helped) and I wanted to walk through some of the things I've learned by expanding on and refining my original query.

I had finished that entry by

wondering how to list

Bart's blackboard entries

for all episodes instead o

for just one season. Vacl

Synace [showed me one](#)

[way](#), and I recently realiz

that there's a much simpl

way—maybe too simple

(all queries shown assum

the namespace declarati

shown on the [SNORQL i](#)

```
SELECT ?blackboard {
  ?s dbpedia2:blackboard
}
```

SPARQL Explorer for htt

SPARQL:

```
PREFIX owl: <http://www.w3.org/2002/07/owl#>
PREFIX xsd: <http://www.w3.org/2001/XMLSchema#>
PREFIX rdfs: <http://www.w3.org/2000/01/rdf-schema#>
PREFIX rdf: <http://www.w3.org/1999/02/22-rdf-syntax-ns#>
PREFIX foaf: <http://xmlns.com/foaf/0.1/>
PREFIX dc: <http://purl.org/dc/elements/1.1/>
PREFIX : <http://dbpedia.org/resource/>
PREFIX dbpedia2: <http://dbpedia.org/property/>
PREFIX dbpedia: <http://dbpedia.org/>
PREFIX skos: <http://www.w3.org/2004/02/skos/core#>
```

```
SELECT ?blackboard WHERE {
  ?s dbpedia2:blackboard ?blackboard.
}
```

Results:

<http://bit.ly/RumkhW>

""Je ne parle pas français""@en
""We are not all naked under our clothes"."@en
"Global Warming did not eat my homework."@en
""Pearls are not oyster barf"."@en
""The Pilgrims were not illegal aliens""@en
""I will not look up what teacher makes.""@en
""I am not an FDIC-insured bank""@en
""The Wall Street Journal is better than ever""@en
""There is no such thing as an iPoddy""@en
"The art teacher is fat, not pregnant."@en
"Teacher did not pay too much for her cond."@en
"There is no such month as "Rocktober"."@en
""Teacher's diet is working.""@en
""The Capital of Montana is not Hannah.""@en
"This punishment is not medieval. ."@en
""I will not use permanent ink on the chalkboard""@en
""Frankincense is not a monster""@en
""HDTV is worth every cent""@en
"I will not mock teacher's outdated cell phone."@en
"I will not put hot sauce in the CPR dummy."@en
"I did not see teacher siphoning gas."@en
"It's "Facebook", not "Assbook"."@en
""Prosperity is just around the corner.""@en
""Four leaf clovers are not mutant freaks""@en

?s

dbpedia2:blackboard

?blackboard

""Je ne parle pas français""@en
""We are not all naked under our clothes"."@en
"Global Warming did not eat my homework."@en
""Pearls are not oyster barf"."@en
""The Pilgrims were not illegal aliens""@en
""I will not look up what teacher makes.""@en
""I am not an FDIC-insured bank""@en
""The Wall Street Journal is better than ever""@en
""There is no such thing as an iPoddy""@en
"The art teacher is fat, not pregnant."@en
"Teacher did not pay too much for her condo."@en
"There is no such month as "Rocktober"."@en
""Teacher's diet is working.""@en
""The Capital of Montana is not Hannah.""@en
"This punishment is not medieval."@en
""I will not use j"@en
""Frankincense"@en
""HDTV is wort"@en
"I will not mock"@en
"I will not put h"@en
"I did not see te"@en
"It's "Facebook"@en
""Prosperity is j"@en
""Four leaf clov

```
SELECT ?s WHERE {  
  ?s dbpedia2:blackboard 'There is no such month as "Rocktober"."@en.'  
}
```

Results:

SPARQL results:

s
:Double,_Double,_Boy_in_Trouble [↗](#)

""Je ne parle pas français""@en
""We are not all naked under our clothes"."@en
"Global Warming did not eat my homework."@en
""Pearls are not oyster barf"."@en
""The Pilgrims were not illegal aliens""@en
""I will not look up what teacher makes.""@en
""I am not an FDIC-insured bank""@en
""The Wall Street Journal is better than ever""@en
""There is no such thing as an iPoddy""@en
"The art teacher is fat, not pregnant."@en
"Teacher did not pay too much for her condo."@en
"There is no such month as "Rocktober"."@en
""Teacher's diet is working.""@en
""The Capital of Montana is not Hannah.""@en
"This punishment is not medieval."@en
""I will not use j"@en
""Frankincense"@en
""HDTV is wort"@en
"I will not mock"@en
"I will not put h"@en
"I did not see te"@en
"It's "Facebook"@en
""Prosperity is j"@en
""Four leaf clov"@en

```
SELECT ?s WHERE {  
  ?s dbpedia2:blackboard 'There is no s'  
}
```

Results:

SPARQL results:

s
:Double,_Double,_Boy_in_Trouble [↗](#)

About: Double, Double, Boy in Trouble

An Entity of Type: Thing, from Named Graph: <http://dbpedia.org>, within Data Space: [db](#)

"Double, Double, Boy in Trouble" is the third episode of the The Simpsons' twentieth season, and first aired on October 1, 2008. In this episode, Bart and Lisa decide to switch homes; Simon enjoys his time with the Simpsons while Bart discovers his rival for the football great Joe Montana guest stars as himself.

Property	Value
dbpedia-owl:abstract	<ul style="list-style-type: none">Double, Double, Boy in Trouble, titulado Doble, doble, niño zozobra en la serie animada Los Simpson, estrenado en Estados Unidos el 19 de octubre de 2008. En su emisión original, el episodio fue interpretándose a sí mismo. En su emisión original, el episodio fue interpretándose a sí mismo. En su emisión original, el episodio fue interpretándose a sí mismo. En su emisión original, el episodio fue interpretándose a sí mismo."Double, Double, Boy in Trouble" is the third episode of the The Simpsons' twentieth season, and first aired on October 1, 2008. In this episode, Bart and Lisa decide to switch homes; Simon enjoys his time with the Simpsons while Bart discovers his rival for the football great Joe Montana guest stars as himself."Dois garotos na maior fria" é o terceiro episódio da 20ª Temporada da série animada Os Simpsons, estreada em 19 de outubro de 2008. Neste episódio, Bart e Lisa decidem trocar de casa; Simon aproveita o tempo com os Simpsons enquanto Bart descobre que seu rival para o futebol Joe Montana faz uma participação especial como ele mesmo.Double, Double, Boy in Trouble är det tredje avsnittet från den tjugoåttende säsongen av den amerikanska serien Simpsons. I denna avsnitt kommer Bart och Lisa att byta bostad; Simon får en rolig tid med Simpsons medan Bart upptäcker att hans rival för fotbollen Joe Montana gäststjärnor som sig själv.L'Échange est le 3Modèle:E épisode de la saison 20 de la série télévisée américaine Les Simpson.
dbpedia-owl:thumbnail	<ul style="list-style-type: none">http://upload.wikimedia.org/wikipedia/commons/thumb/d/d1/Double
dbpprop:airdate	<ul style="list-style-type: none">2008-10-19 (xsd:date)
dbpprop:blackboard	<ul style="list-style-type: none">There is no such month as "Rocktober".
dbpprop:couchGag	<ul style="list-style-type: none">In a parody of The Wizard of Oz, the family gets in a tornado accident.
dbpprop:director	<ul style="list-style-type: none">dbpedia:Michael_Polcino
dbpprop:episodeName	<ul style="list-style-type: none">Double, Double, Boy in Trouble
dbpprop:episodeNo	<ul style="list-style-type: none">423 (xsd:integer)
dbpprop:guestStar	<ul style="list-style-type: none">dbpedia:Joe_Montana
dbpprop:imageCaption	<ul style="list-style-type: none">Bart meets his double.
dbpprop:prodCode	<ul style="list-style-type: none">KARF14

""Je ne parle pas français""@en
 ""We are not all naked under our clothes"."@en
 "Global Warming did not eat my homework."@en
 ""Pearls are not oyster barf"."@en
 ""The Pilgrims were not illegal aliens""@en
 ""I will not look up what teacher makes.""@en
 ""I am not an FDIC-insured bank""@en
 ""The Wall Street Journal is better than ever""@en
 ""There is no such thing as an iPoddy""@en
 "The art teacher is fat, not pregnant."@en
 "Teacher did not pay too much for her condo."@en
 "There is no such month as "Rocktober"."@en
 ""Teacher's diet is working.""@en
 ""The Capital of Montana is not Hannah.""@en
 "This punishment is not medieval."@en
 ""I will not use j..."
 ""Frankincense..."
 ""HDTV is wort..."
 "I will not mock..."
 "I will not put h..."
 "I did not see te..."
 "It's "Facebook..."
 ""Prosperity is j..."
 ""Four leaf clov...

```

SELECT ?s WHERE {
  ?s dbpedia2:blackboard 'There is no s
}
  
```

Results:

SPARQL results:

About: Double, Double, Boy in Trouble

An Entity of Type: Thing from Named Graph: <http://dbpedia.org>, within Data Space: [db](#)

"Double, Double, Boy in Trouble" is the third episode of the The Simpsons' twentieth season, and first aired on October 19, 2008. In this episode, Bart and Lisa decide to switch homes; Simon enjoys his time with the Simpsons while Bart discovers his rival for the football great Joe Montana guest stars as himself.

Property	Value
dbpedia-owl:abstract	<ul style="list-style-type: none"> Double, Double, Boy in Trouble. titulado Doble, doble, niño zozobra el 19 de octubre de 2008. Debido a ello, para así celebrar el episodio fue... "Double, Double, Boy in Trouble" is the third episode of the The Simpsons' twentieth season, and first aired on October 19, 2008. In this episode, Bart and Lisa decide to switch homes; Simon enjoys his time with the Simpsons while Bart discovers his rival for the football great Joe Montana guest stars as himself. For 1.5 million viewers. "Dois garotos na maior fria" é o terceiro episódio da 20ª Temporada da série. Double, Double, Boy in Trouble är det tredje avsnittet från den tjugoårstionde till den nittonde säsongen men blev istället uppskjutet till den tjugonde under ett par veckor. L'Échange est le 3Modèle:E épisode de la saison 20 de la série télévisée.
dbpedia-owl:thumbnail	<ul style="list-style-type: none"> http://upload.wikimedia.org/wikipedia/commons/thumb/d/d1/Double
dbpprop:airdate	<ul style="list-style-type: none"> 2008-10-19 (xsd:date)
dbpprop:blackboard	<ul style="list-style-type: none"> There is no such month as "Rocktober".
dbpprop:couchGag	<ul style="list-style-type: none"> In a parody of The Wizard of Oz, the family gets in a tornado accident.
dbpprop:director	<ul style="list-style-type: none"> dbpedia:Michael_Polcino
dbpprop:episodeName	<ul style="list-style-type: none"> Double, Double, Boy in Trouble
dbpprop:episodeNo	<ul style="list-style-type: none"> 423 (xsd:integer)
dbpprop:guestStar	<ul style="list-style-type: none"> dbpedia:Joe_Montana
dbpprop:imageCaption	<ul style="list-style-type: none"> Bart meets his double.
dbpprop:prodCode	<ul style="list-style-type: none"> KABF14

[http://dbpedia.org/resource/Double, Double, Boy in Trouble](http://dbpedia.org/resource/Double,_Double,_Boy_in_Trouble)

LOGD Tutorial SPARQL Query

```
# this query returns the agi and population data from two data.gov datasets

SELECT distinct ?state_abbrev ?agi ?population
WHERE {
  GRAPH <http://logd.tw.rpi.edu/source/data-gov/dataset/353/version/1st-anniversary>{

    ?s1 <http://logd.tw.rpi.edu/source/data-gov/dataset/353/vocab/raw/population_st> ?population.
    ?s1 <http://logd.tw.rpi.edu/source/data-gov/dataset/353/vocab/raw/pub_fips> ?state_fipscode .
  }
  GRAPH <http://logd.tw.rpi.edu/source/data-gov/dataset/1356/version/2009-Dec-03> {
    ?s2 <http://logd.tw.rpi.edu/source/data-gov/dataset/1356/vocab/raw/state_abbrev> ?state_abbrev .
    ?s2 <http://logd.tw.rpi.edu/source/data-gov/dataset/1356/vocab/raw/county_code> "000" .
    ?s2 <http://logd.tw.rpi.edu/source/data-gov/dataset/1356/vocab/raw/agi> ?agi.
    ?s2 <http://logd.tw.rpi.edu/source/data-gov/dataset/1356/vocab/raw/state_code> ?state_fipscode .
  }
}
order by ?state_fipscode
```

SPARQL Query (results)

SPARQLer Query Results

state_abbv	agi	population
"AL"	"92162773"	"4599030"
"AK"	"17312636"	"670053"
"AZ"	"134442007"	"6166318"
"AR"	"49783294"	"2810872"
"CA"	"913619942"	"36457549"
"CO"	"128175529"	"4753377"
"CT"	"122697142"	"3504809"
"DE"	"22983204"	"853476"
"DC"	"18177370"	"581530"
"FL"	"429785960"	"18089888"
"GA"	"199864840"	"9363941"
"HI"	"30592983"	"1285498"
"ID"	"30292717"	"1466465"
"IL"	"339217881"	"12831970"
"IN"	"140616570"	"6313520"
"IA"	"68946837"	"2982085"
"KS"	"65216515"	"2764075"
"KY"	"81721206"	"4206074"
"LA"	"84029967"	"4287768"
"ME"	"28954363"	"1321574"

"MD"	"168647138"	"5615727"
"MA"	"202226349"	"6437193"
"MI"	"227233854"	"10095643"
"MN"	"143482070"	"5167101"
"MS"	"47387966"	"2910540"
"MO"	"131166510"	"5842713"
"MT"	"20045504"	"944632"
"NE"	"41569440"	"1768331"
"NV"	"65272642"	"2495529"
"NH"	"38175000"	"1314895"
"NJ"	"283024874"	"8724560"
"NM"	"38144029"	"1954599"
"NY"	"513598458"	"19306183"
"NC"	"195374554"	"8856505"
"ND"	"14923738"	"635867"
"OH"	"259099675"	"11478006"
"OK"	"70394493"	"3579212"
"OR"	"85591882"	"3700758"
"PA"	"313289892"	"12440621"
"RI"	"26532233"	"1067610"
"SC"	"88615194"	"4321249"
"SD"	"17825580"	"781919"
"TN"	"126270760"	"6038803"
"TX"	"504386602"	"23507783"

"UT"	"55426179"	"2550063"
"VT"	"15246152"	"623908"
"VA"	"217677476"	"7642884"
"WA"	"175730868"	"6395798"
"WV"	"32243697"	"1818470"
"WI"	"140516394"	"5556506"
"WY"	"15216840"	"515004"

SPARQL Query results (JSON)

```
google.visualization.Query.setResponse({version:0.6,status:'ok',reqId:0,table:{cols:[{id:'state_abbv',label:'state_abbv',type:'string'},{id:'agi',label:'agi',type:'number'},{id:'population',label:'population',type:'number'}],rows:[{c:[{v:'AL'},{v:92162773},{v:4599030}]}, {c:[{v:'AK'},{v:17312636},{v:670053}]}, {c:[{v:'AZ'},{v:134442007},{v:6166318}]}, {c:[{v:'AR'},{v:49783294},{v:2810872}]}, {c:[{v:'CA'},{v:913619942},{v:36457549}]}, {c:[{v:'CO'},{v:128175529},{v:4753377}]}, {c:[{v:'CT'},{v:122697142},{v:3504809}]}, {c:[{v:'DE'},{v:22983204},{v:853476}]}, {c:[{v:'DC'},{v:18177370},{v:581530}]}, {c:[{v:'FL'},{v:429785960},{v:1808988}]}, {c:[{v:'GA'},{v:199864840},{v:9363941}]}, {c:[{v:'HI'},{v:30592983},{v:1285498}]}, {c:[{v:'ID'},{v:30292717},{v:1466465}]}, {c:[{v:'IL'},{v:339217881},{v:12831970}]}, {c:[{v:'IN'},{v:140616570},{v:6313520}]}, {c:[{v:'IA'},{v:68946837},{v:2982085}]}, {c:[{v:'KS'},{v:65216515},{v:2764075}]}, {c:[{v:'KY'},{v:81721206},{v:4206074}]}, {c:[{v:'LA'},{v:84029967},{v:4287768}]}, {c:[{v:'ME'},{v:28954363},{v:1321574}]}, {c:[{v:'MD'},{v:168647138},{v:5615727}]}, {c:[{v:'MA'},{v:202226349},{v:6437193}]}, {c:[{v:'MI'},{v:227233854},{v:10095643}]}, {c:[{v:'MN'},{v:143482070},{v:5167101}]}, {c:[{v:'MS'},{v:47387966},{v:2910540}]}, {c:[{v:'MO'},{v:131166510},{v:5842713}]}, {c:[{v:'MT'},{v:20045504},{v:944632}]}, {c:[{v:'NE'},{v:41569440},{v:1768331}]}, {c:[{v:'NV'},{v:65272642},{v:2495529}]}, {c:[{v:'NH'},{v:38175000},{v:1314895}]}, {c:[{v:'NJ'},{v:283024874},{v:8724560}]}, {c:[{v:'NM'},{v:38144029},{v:1954599}]}, {c:[{v:'NY'},{v:513598458},{v:19306183}]}, {c:[{v:'NC'},{v:195374554},{v:8856505}]}, {c:[{v:'ND'},{v:14923738},{v:635867}]}, {c:[{v:'OH'},{v:259099675},{v:11478006}]}, {c:[{v:'OK'},{v:70394493},{v:3579212}]}, {c:[{v:'OR'},{v:85591882},{v:3700758}]}, {c:[{v:'PA'},{v:313289892},{v:12440621}]}, {c:[{v:'RI'},{v:26532233},{v:1067610}]}, {c:[{v:'SC'},{v:88615194},{v:4321249}]}, {c:[{v:'SD'},{v:17825580},{v:781919}]}, {c:[{v:'TN'},{v:126270760},{v:6038803}]}, {c:[{v:'TX'},{v:504386602},{v:23507783}]}, {c:[{v:'UT'},{v:55426179},{v:2550063}]}, {c:[{v:'VT'},{v:15246152},{v:623908}]}, {c:[{v:'VA'},{v:217677476},{v:7642884}]}, {c:[{v:'WA'},{v:175730868},{v:6395798}]}, {c:[{v:'WV'},{v:32243697},{v:1818470}]}, {c:[{v:'WI'},{v:140516394},{v:5556506}]}, {c:[{v:'WY'},{v:15216840},{v:515004}]})})
```

<http://logd.tw.rpi.edu/demo/building-logd-visualizations/mashup-353-population-1356-agi.js>

SPARQL Query results (JSON)

```
google.visualization.Query.setResponse({version:0.6,status:'ok',reqId:0,table:{cols:[{id:'state_abbrev',label:'state_abbrev',type:'string'},{id:'agi',label:'agi',type:'number'},{id:'population',label:'population',type:'number'}],rows:[{c:[{v:'AL'},{v:92162773},{v:4599030}]},{c:[{v:'AK'},{v:17312636},{v:670053}]},{c:[{v:'AZ'},{v:134442007},{v:6166318}]},{c:[{v:'AR'},{v:49783294},{v:2810872}]},{c:[{v:'CA'},{v:913619942},{v:36457549}]},{c:[{v:'CO'},{v:128175529},{v:4753377}]},{c:[{v:'CT'},{v:122697142},{v:3504809}]},{c:[{v:'DE'},{v:22983204},{v:853476}]},{c:[{v:'DC'},{v:18177370},{v:581530}]},{c:[{v:'FL'},{v:429785960},{v:1808988}]},{c:[{v:'GA'},{v:199864840},{v:9363941}]},{c:[{v:'HI'},{v:30592983},{v:1285498}]},{c:[{v:'ID'},{v:30292717},{v:1466465}]},{c:[{v:'IL'},{v:339217881},{v:12831970}]},{c:[{v:'IN'},{v:140616570},{v:6313520}]},{c:[{v:'IA'},{v:68946837},{v:2982085}]},{c:[{v:'KS'},{v:65216515},{v:2764075}]},{c:[{v:'KY'},{v:81721206},{v:4206074}]},{c:[{v:'LA'},{v:84029967},{v:4287768}]},{c:[{v:'ME'},{v:28954363},{v:1321574}]},{c:[{v:'MD'},{v:168647138},{v:5615727}]},{c:[{v:'MA'},{v:202226349},{v:6437193}]},{c:[{v:'MI'},{v:227233854},{v:10095643}]},{c:[{v:'MN'},{v:143482070},{v:5167101}]},{c:[{v:'MS'},{v:47387966},{v:2910540}]},{c:[{v:'MO'},{v:131166510},{v:5842713}]},{c:[{v:'MT'},{v:20045504},{v:944632}]},{c:[{v:'NE'},{v:41569440},{v:1768331}]},{c:[{v:'NV'},{v:65272642},{v:2495529}]},{c:[{v:'NH'},{v:38175000},{v:1314895}]},{c:[{v:'NJ'},{v:283024874},{v:8724560}]},{c:[{v:'NM'},{v:38144029},{v:1954599}]},{c:[{v:'NY'},{v:513598458},{v:19306183}]},{c:[{v:'NC'},{v:195374554},{v:8856505}]},{c:[{v:'ND'},{v:14923738},{v:635867}]},{c:[{v:'OH'},{v:259099675},{v:11478006}]},{c:[{v:'OK'},{v:70394493},{v:3579212}]},{c:[{v:'OR'},{v:85591882},{v:3700758}]},{c:[{v:'PA'},{v:313289892},{v:12440621}]},{c:[{v:'RI'},{v:26532233},{v:1067610}]},{c:[{v:'SC'},{v:88615194},{v:4321249}]},{c:[{v:'SD'},{v:17825580},{v:781919}]},{c:[{v:'TN'},{v:126270760},{v:6038803}]},{c:[{v:'TX'},{v:504386602},{v:23507783}]},{c:[{v:'UT'},{v:55426179},{v:2550063}]},{c:[{v:'VT'},{v:15246152},{v:623908}]},{c:[{v:'VA'},{v:217677476},{v:7642884}]},{c:[{v:'WA'},{v:175730868},{v:6395798}]},{c:[{v:'WV'},{v:32243697},{v:1818470}]},{c:[{v:'WI'},{v:140516394},{v:5556506}]},{c:[{v:'WY'},{v:15216840},{v:515004}]}]}
```

<http://logd.tw.rpi.edu/demo/building-logd-visualizations/mashup-353-population-1356-agi.js>

Defining HTML Layout

```
<!DOCTYPE html PUBLIC "-//W3C//DTD XHTML 1.0 Strict//EN"
    "http://www.w3.org/TR/xhtml1/DTD/xhtml1-strict.dtd">
<html xmlns="http://www.w3.org/1999/xhtml">
  <head>
    <title>AGI per Capita Map</title>
  </head>
  <body>
    <div>AGI per Capita Map: average adjusted gross income per person in
dollar amount in US states.</div>
    <div id='map_canvas'>Loading Map ...</div>
  </body>
</html>
```

http://logd.tw.rpi.edu/tutorial/building_logd_visualizations

Visualization Code...

1. Load the appropriate Google Visualization API packages (in this case, the **GeoMap package**).
2. Define a callback function for loading visualization code, which is called upon the loading of the HTML page.
3. Obtain data from a given source to pass to our GeoMap instance. The Google Visualization API is designed to accept data in the form of specially-formatted JSON (represented by a [URI](#)) which can then be fed to a JSON processing function.
4. Following a call to the JSON processor, verify that it successfully processed the passed file.
5. Get back a response from the query processor, containing the data from the JSON file.
6. Define a data table to store the response data in. This process starts by defining header entries of the form
`TABLE.addColumn(DATATYPE, NAME).`

http://logd.tw.rpi.edu/tutorial/building_logd_visualizations

Visualization

1. Load the appropriate Google \
2. Define a callback function for l
3. Obtain data from a given sourc
in the form of specially-formatt
4. Following a call to the JSON p
5. Get back a response from the
6. Define a data table to store the

```
<!-- import Google visualization API -->
<script type="text/javascript" src="http://www.google.com/jsapi"></script>

<!-- customize function -->
<script type="text/javascript">
/*  */

// load google visualization packages - STEP 1
google.load('visualization', '1', {'packages': ['geomap']});

// set callback function for drawing visualizations - STEP 2
google.setOnLoadCallback(drawMap);

function drawMap() {
//load static data - STEP 3
var queryurl = "http://logd.tw.rpi.edu/demo/building-logd-visualizations/mashup-353-population-1356-agi.js";
var query = new google.visualization.Query(queryurl); // Send the query.
query.send(handleQueryResponse);
}

function handleQueryResponse(response){
// Check for query response errors. - STEP 4
if (response.isError()) {
alert('Error in query: ' + response.getMessage() + ' ' + response.getDetailedMessage());
return;
}

// read data - STEP 5
var data = response.getDataTable();

// create new data - STEP 6
var newdata = new google.visualization.DataTable();
newdata.addColumn('string', 'State');
newdata.addColumn('number', 'AGI per Capita');

// populate each row - STEP 7
var rows = data.getNumberOfRows();
for (var i = 0; i &lt; rows; i++)
{
var state = 'US-' + data.getValue(i, 0);
var value = Math.round(data.getValue(i, 1)*1000/data.getValue(i, 2)); // AGI figure uses thousand-dollar unit
newdata.addRow([state, value]);
}

// configure map options - STEP 8
var options = {};
options['region'] = 'US'; // show US map
options['dataMode'] = 'regions';
options['width'] = 900;
options['height'] = 550;

// define geomap instance - STEP 9
var viz = document.getElementById('map_canvas');
new google.visualization.GeoMap(viz).draw(newdata, options );

}
/* ]]&gt; */
&lt;/script&gt;</pre></div><div data-bbox="6 926 314 970" data-label="Text"><p><a href="http://logd.tw.rpi.edu/tutorial/building">http://logd.tw.rpi.edu/tutorial/building</a></p></div>
```

Dynamic Visualizations

Loading data using SPARQL queries

```
//load data using SPARQL query
var sparqlproxy = "http://logd.tw.rpi.edu/ws/sparqlproxy.php";
var queryloc = "http://logd.tw.rpi.edu/demo/building-logd-visualizations/mashup-353-  
population-1356-agi.sparql";
var service = "http://logd.tw.rpi.edu/sparql";
var queryurl = sparqlproxy
    + "?" + "output=gvds"
    + "&service-uri=" + encodeURIComponent(service)
    + "&query-uri=" + encodeURIComponent(queryloc) ;
```

Advanced Concepts

Vocabulary design/RDFS
Knowledge Organization
Ontology design
Provenance
Inference

For a poetic (and humorous!) consideration of the evolution of the "Semantic Layer Cake" see:
Jim Hendler, "My Take on the Semantic Web Layer Cake." <http://bit.ly/195L70i>

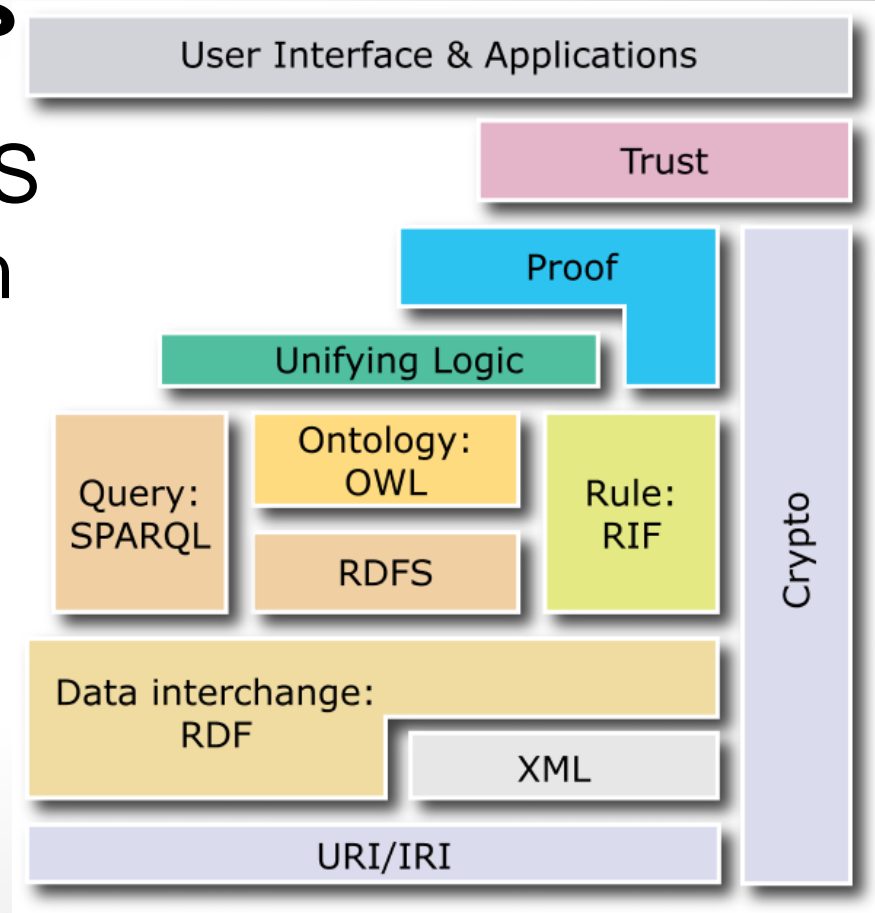

Inference: Discovering New Relationships

On the Semantic Web, data is modeled as a set of (named) relationships between resources

Inference means using automatic procedures to generate **new relationships** based on the data...

...and some **additional information** in the form of a **vocabulary** or a **set of rules**

The new relationships may **explicitly added** to the set of data, or may be **returned at query time** (implementation issue)

The source of **additional information** is defined through vocabularies or rule sets

Both approaches draw upon **knowledge representation** techniques

Ontologies provide classification methods, putting an emphasis on defining 'classes', 'subclasses', on how individual resources can be associated to such classes, and characterizing the relationships among classes and their instances

Rules define mechanisms for discovering and generating new relationships based on existing ones, much like logic programs (Prolog)

In the Semantic Web toolkit, **RDFS**, **OWL**, or **SKOS** are used for defining ontologies

RIF covers rule based approaches

Vocabulary Design: W3C RDFS

RDF Vocabulary Description Language

RDF has no mechanism for:

- describing properties

- describing the relationships between properties and other resources

RDF Schema defines classes and properties for describing classes, properties and other resources

RDF Schema vocabulary descriptions are written in RDF

<http://www.w3.org/TR/2004/REC-rdf-schema-20040210/>

RDF Schema: Classes

rdfs:Resource ...is the class of everything

rdfs:Class ...declares a resource as a class for other resources

rdfs:Literal ...literal values such as strings and integers

rdfs:Datatype ...the class of datatypes

rdf:XMLLiteral ...the class of XML literal values

rdf:Property ...the class of properties

RDF Schema: Properties

rdfs:domain ...declares the class of the subject in a triple whose second component is the predicate.

rdfs:range ...declares the class or datatype of the object in a triple whose second part is the predicate

ex:employer rdfs:domain foaf:Person

ex:employer rdfs:range foaf:Organization

rdf:type ...state that resource is an instance of a class

rdfs:subClassOf ...allows to declare hierarchies of classes.

e.g. "Every Person is an Agent": foaf:Person rdfs:subClassOf foaf:Agent

rdfs:subPropertyOf ...states that all resources related by one property are also related by another

rdfs:label ...used to provide a human-readable version of a resource's name

rdfs:comment ...provides a human-readable description of a resource

rdfs:seeAlso ...indicates a resource that might provide additional information about the subject resource.

rdfs:isDefinedBy ...indicates a resource defining the subject resource

<http://www.w3.org/TR/2004/REC-rdf-schema-20040210/>

Knowledge Organization: W3C OWL

Web Ontology Language

RDFS too weak to describe resources in sufficient detail

- No localised range and domain constraints

 - Can't say that the range of hasChild is person when applied to persons and elephant when applied to elephants

- No existence/cardinality constraints

 - Can't say that all instances of person have a mother that is also a person, or that persons have exactly 2 parents

- No transitive, inverse or symmetrical properties

 - Can't say that isPartOf is a transitive property, that hasPart is the inverse of isPartOf or that touches is symmetrical

Difficult to provide reasoning support

- No "native" reasoners for non-standard semantics

Knowledge Organization: W3C OWL

Desirable features identified for Web Ontology Language:

- Extends existing Web standards

 - Such as XML, RDF, RDFS

- Easy to understand and use

 - Should be based on familiar KR* idioms

- Formally specified

- Of “adequate” expressive power

- Possible to provide automated reasoning support

KR* = knowledge representation

OWL Tools: Protege-OWL Editor

The image displays two overlapping windows of the Protege-OWL Editor. The left window shows the 'SUBCLASS RELATIONSHIP' view for the project 'travel'. It features two panes: 'Asserted Hierarchy' and 'Inferred Hierarchy'. The 'Asserted Hierarchy' pane shows a tree structure starting with 'Destination' as the root, with children including 'BackpackersDestination', 'Beach', 'BudgetHotelDestination', 'FamilyDestination', 'QuietDestination', 'RetireeDestination', 'RuralArea', 'UrbanArea', and 'City'. The 'RetireeDestination' class has a child 'Capital'. The 'Inferred Hierarchy' pane shows a similar structure but includes 'Town' as a child of 'City'. Below these panes is a 'Class' table with columns for class names and their relationships.

Class	Relationship
Campground	Moved from Accommodation
Capital	Added RetireeDestination
NationalPark	Added BackpackersDestination
RetireeDestination	Moved from Destination

The right window shows the 'CLASS BROWSER' view for the project 'travel'. It displays a graph of the class hierarchy. The 'Destination' class is the central node, with arrows pointing to it from its subclasses: 'RuralArea', 'UrbanArea', 'BudgetHotelDestination', 'RetireeDestination', 'Beach', 'FamilyDestination', 'QuietDestination', 'BackpackersDestination', and 'Surfing'. The 'RuralArea' class has subclasses 'Farmland' and 'NationalPark'. The 'UrbanArea' class has subclasses 'Town' and 'City'. The 'City' class has a subclass 'Capital'. The 'AccommodationRating' class is also shown, with a relationship to 'Destination'. A legend in the bottom right corner explains the symbols used in the graph: a solid line for 'NECESSARY & SUFFICIENT', a line with a circle for 'hasAccommodation BudgetAccommodation', and a line with a square for 'hasActivity (Sports Adventure)'. The legend also indicates 'NECESSARY' and 'SUFFICIENT' conditions.

Knowledge Organization: W3C SKOS

Simple Knowledge Organization System

An application of RDFS and OWL

Provides a way to represent controlled vocabularies, taxonomies and thesauri

controlled vocabulary: a list of terms which a community or organization has agreed upon

taxonomy: a controlled vocabulary organized in a hierarchy

thesaurus: a taxonomy with more information about each concept including preferred and alternative terms.

A thesaurus may also contain relationships to related concepts

SKOS is an OWL ontology; it can be written out in any RDF syntax

Provenance: The W3C PROV Model

A set of W3C recommendations and notes on modelling provenance
PROV-O is the "core..."

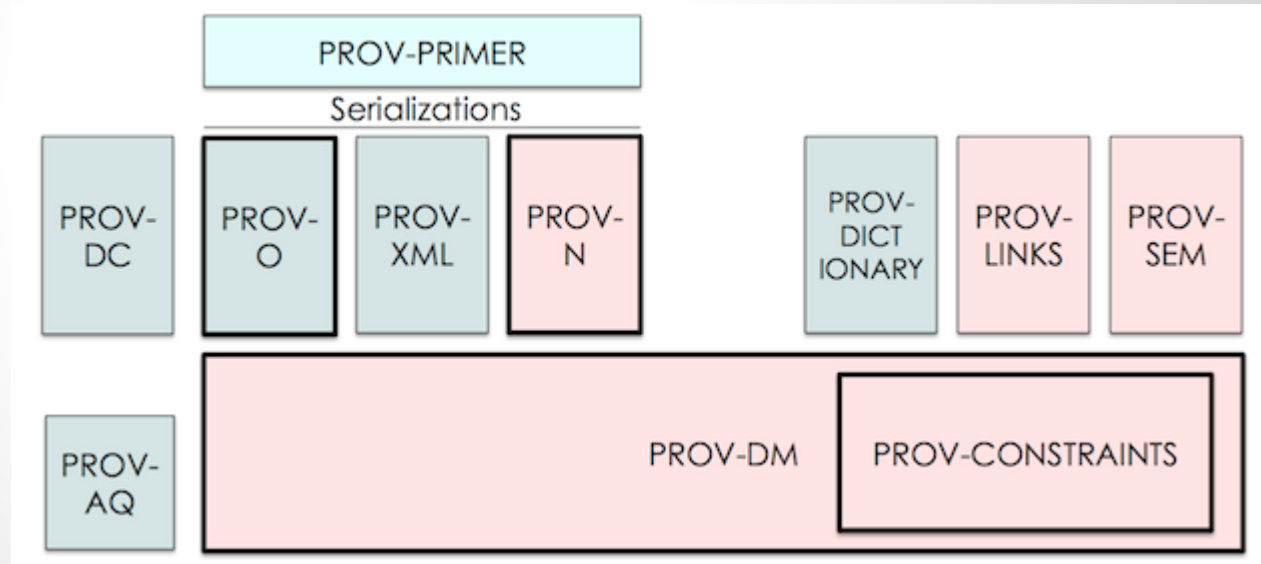

Provenance in a Nutshell

prov:Entity is a physical, digital, conceptual, or other kind of thing with some fixed aspects; entities may be real or imaginary

prov:Activity is something that occurs over a period of time and acts upon or with entities; it may include consuming, processing, transforming, modifying, relocating, using, or generating entities

prov:Agent is something that bears some form of responsibility for an activity taking place, for the existence of an entity, or for another agent's activity

These three classes provide a basis for the rest of PROV-O

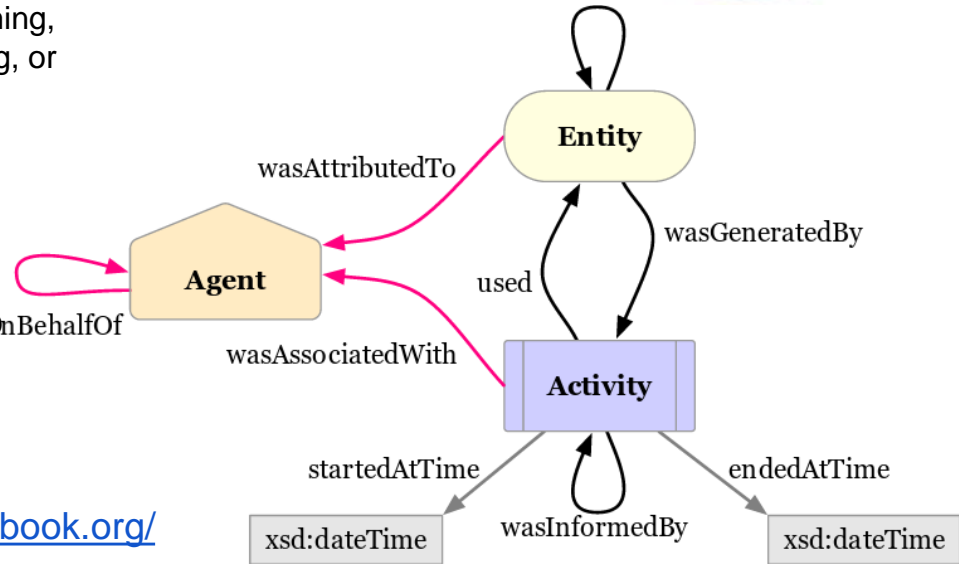

<http://www.w3.org/TR/prov-primer/> or <http://www.provbook.org/>

Inference and W3C RIF

Production Rules

Analogous to instruction in a program: If a certain condition holds, then some action is carried out

Example: "If a customer has flown more than 100,000 miles, then upgrade him to Gold Member status."

Declarative Rules

Stating a fact about the world

Understood as sentences of the form "If P, then Q"

Example: "If a person is currently president of the United States of America, then his or her current residence is the White House."

There are many rule systems, esp. in the expert systems domain
The W3C **Rule Interchange Format** is an interchange format between existing rule systems

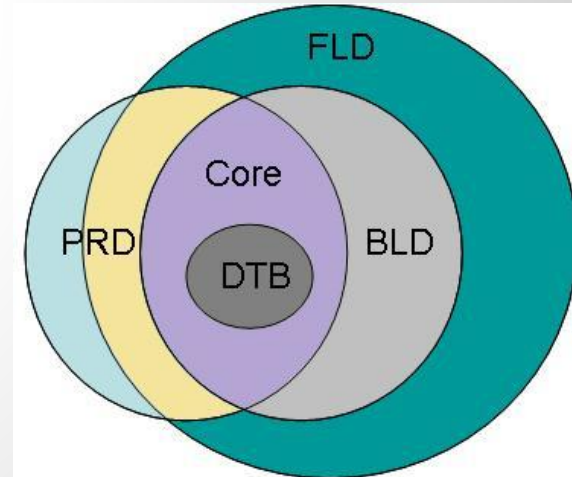

The Future....

Semantics of Information Connections

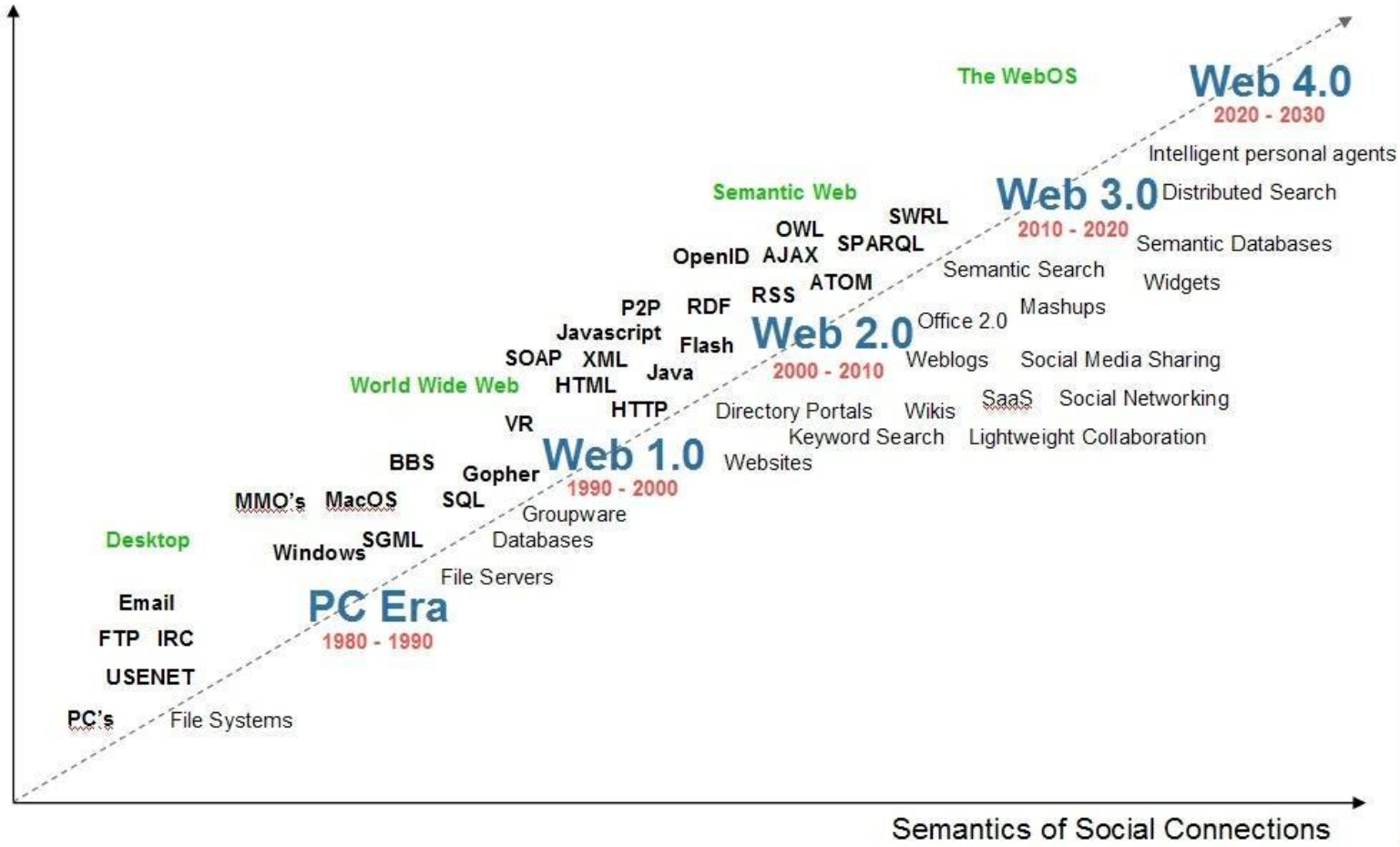

Semantics of Social Connections



Source: Radar Networks & Nova Spivack, 2007 – www.radarnetworks.com

How can the Semantic Web be used to improve Healthcare?

- Interoperability of electronic record systems
- Knowledge representation of medical experts
- Data analytics



What is Semantic Interoperability?

Semantic interoperability is the ability to exchange data with unambiguous, shared meaning. Semantic interoperability is a requirement to enable machine computable logic, inferencing, knowledge discovery, and data federation between information systems.

Semantic interoperability is therefore concerned not just with the packaging of data (syntax), but the simultaneous transmission of the meaning with the data (semantics).

This is accomplished by adding data about the data (metadata), linking each data element to a controlled, shared vocabulary. The meaning of the data is transmitted with the data itself, in one self-describing "information package" that is independent of any information system.

It is this shared vocabulary, and its associated links to an ontology, which provides the foundation and capability of machine interpretation, inferencing, and logic.

Syntactic interoperability is a prerequisite for semantic interoperability. Syntactic interoperability refers to the packaging and transmission mechanisms for data. In healthcare, HL7 has been in use for over thirty years to provide syntactic interoperability.

https://en.wikipedia.org/wiki/Semantic_interoperability

Interoperability of Electronic Health Records (EHRs)

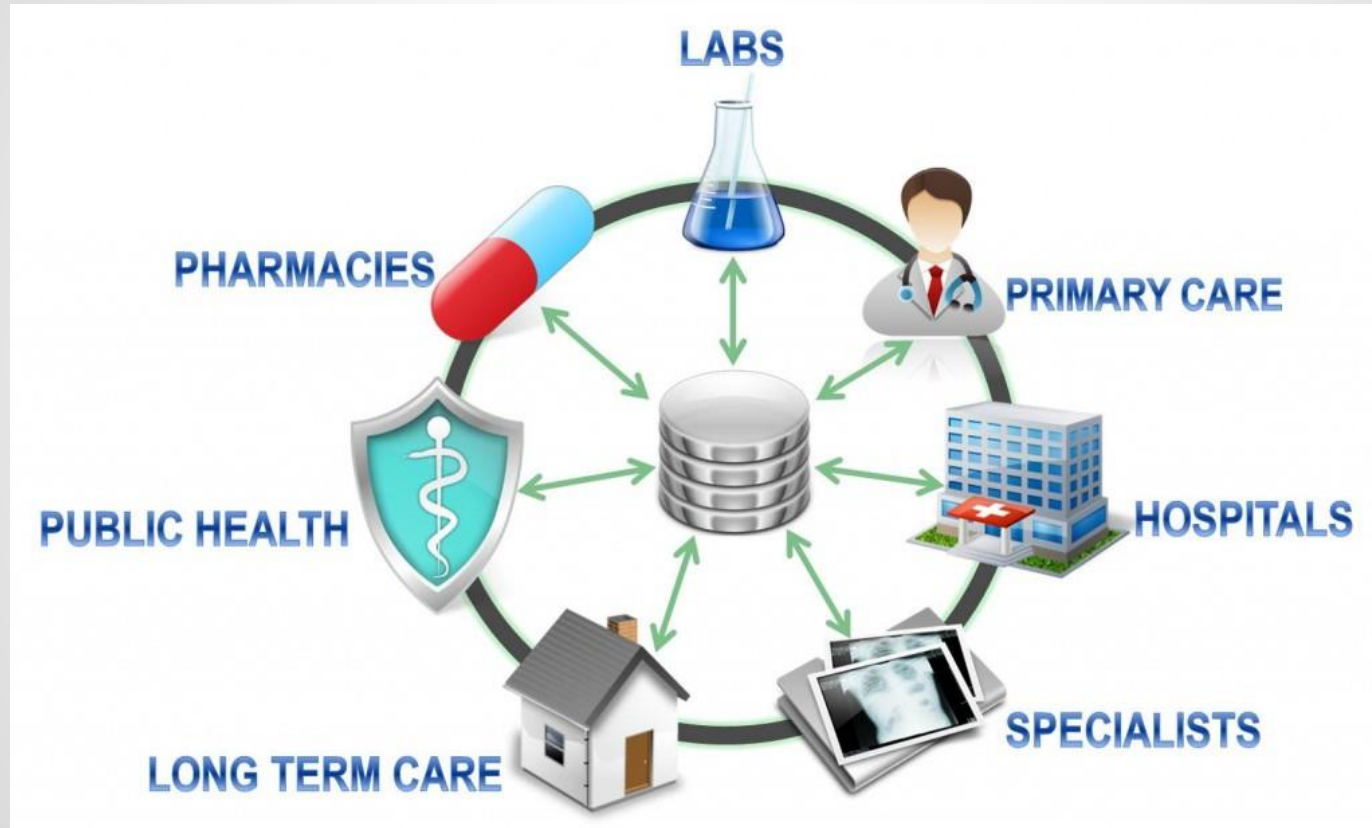

Cleveland Clinic Use Case

Improve the Clinic's ability to **use patient data for generating new knowledge** to improve future patient care through outcomes-based and longitudinal clinical research.

Leverage expressiveness and versatility of formats to provide individual patients an appropriate terminology and accessible view of summary data.

Over 4 years, Cleveland Clinic has developed a **representational methodology** for bridging data collection, document management, and knowledge representation.

The result is a unified content repository called **SemanticDB**.

Cleveland Clinic Use Case

- SemanticDB internally deployed for production on top of an open source XML & RDF content repository and Firefox (with extensions).
- Methodology realized through a core set of terms that facilitate creation of a domain vocabulary (or domain model) instances of the vocabulary managed automatically by the system.
- Patient records available as both uniform, structured markup and RDF.
- Coordinated use of both representation languages enables a variety of operations on patient record:
 - form-based data entry, transformation to reporting formats, document validation, targeted inference, and querying
 - Operations can be dispatched on the patient record documents and RDF graphs over a uniform set of interfaces.

Medical Expert System

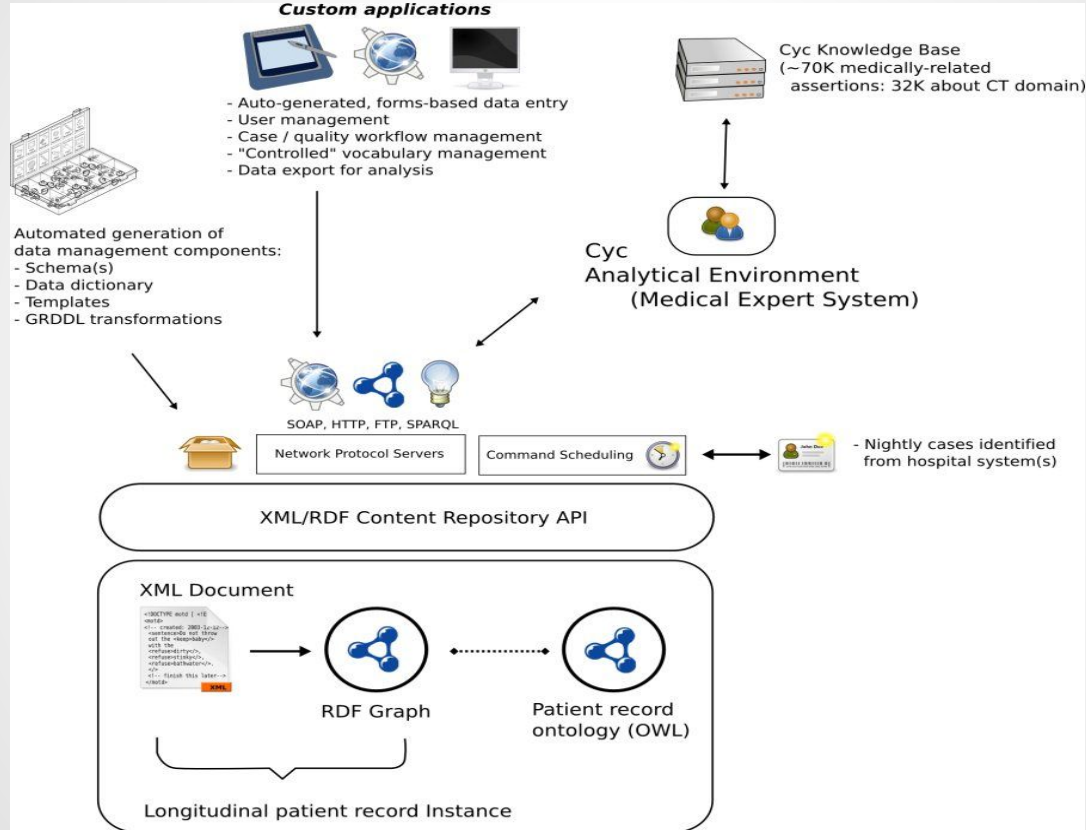

Cyc Analytical Environment: Generic Medical Research Task Allotment

File Edit Tools Window Help

Task Info Document Search Concepts Queries

What patients were diagnosed with a Hiatal Hernia after an operation that employe Find Stop

Search Results

What patients were diagnosed with a Hiatal Hernia after an operation that employed a femoral percutaneous surgical incision?

Simple Questions

- _____ is the patient involved in _____.
- The patient ID for _____ is _____.
- _____ occurred in operations.
- _____ is an operation.
- _____ is a femoral percutaneous surgical incision.
- _____ comes about during a femoral percutaneous surgical incision.
- The type of surgical incision employed in _____ is femoral percutaneous surgical incisions.
- During the event _____ the diagnosis indicates hiatal hernia.
- _____ is before _____.
- _____ is a surgical procedure performed during _____.
- _____ contains _____.

Simple Question Templates

- _____ occurred _____.
- _____ comes about _____.
- The type of surgical _____ is _____.
- During the event _____ the diagnosis indicates _____.

Keyword Search

CCF Query Library

- CCF Query Fragments
- CCF Example queries

Status: idle Message:

Copy Query Text
Open
Delete
Combine selected queries
Attempt to combine the two queries

Cyc Analytical Environment: Generic Medical Research Task Allotment

File Edit Tools Window Help

Task Info Document Search Concepts Queries

Give the values of *CCF-MANAGEMENT-EVENT*, *ELAPSED-TIME-712*, *SURGICAL-PROCEDURE*, *CCF-EVALUATION-EVENT* and *ID* such that:

- All of the following are true
 - The patient ID for *PATIENT* is *ID*.
 - The type of surgical incision employed in *CCF-MANAGEMENT-EVENT* is femoral percutaneous surgical incisions.
 - CCF-MANAGEMENT-EVENT* is an operation.
 - PATIENT* is the patient involved in *CCF-MANAGEMENT-EVENT*.
 - SURGICAL-PROCEDURE* is a surgical procedure performed during *CCF-MANAGEMENT-EVENT*.
 - During the event *CCF-EVALUATION-EVENT* the diagnosis indicates hiatal hernia.
 - PATIENT* is the patient involved in *CCF-EVALUATION-EVENT*.
 - CCF-MANAGEMENT-EVENT* is before *CCF-EVALUATION-EVENT*.
 - CCF-EVALUATION-EVENT* happened between 1989 and 2006.
 - CCF-MANAGEMENT-EVENT* started *ELAPSED-TIME-712* before or after *CCF-EVALUATION-EVENT*.
 - ELAPSED-TIME-712* is less than 2 months.

Ask
Save
New Tab
Stop

Palette

CCF-EVALUATION-E...
CCF-MANAGEMENT...
PATIENT

between 1989 and 2006
CCF-MANAGEMENT... < 2 months CCF-EVALUATION-E...

Allow speculation?

Answers

Ccf management event	Surgical procedure	Id	Ccf evaluation event

Justify Fact Sheet Visualize Visualize All

Status: Idle Message:



Tetherless World Constellation



Rensselaer

Tetherless World Constellation

View

View Source



What is TWC?

The **Tetherless World Constellation (TWC)** at **Rensselaer Polytechnic Institute (RPI)** is a constellation of multidisciplinary researchers who study the scientific and engineering principles that underlie the Web, to enhance the Web's reach beyond the desktop and laptop computer, and develops new technologies and languages that expand the capabilities of the Web under three themes: Future Web, Xinformatics and Semantic Foundations.

TWC goals include making the next generation web natural to use while being responsive to the growing variety of policy, educational, societal, and scientific needs. Research areas include: web science, privacy, intellectual property, general compliance, Web-based medical and health systems, semantic escience, data-science, semantic data frameworks, next generation virtual observatories, semantic data and knowledge integration, ontologies, semantic rules and query, semantic applications, data and information visualization, and knowledge provenance, trust and explanation for science. [More...]

TWC In Action



Tim Berners-Lee (center) congratulates TWC PhD recipients Greg Williams (left) and Jesse Weaver (right) during a March 2013 visit.



[Home](#) > [News](#) > [Academics](#) > [Rensselaer Launches Initiative...](#)

Rensselaer Polytechnic Institute Launches Initiative on Healthy Birth, Growth, and Development Knowledge: Semantic and Data Analytic Support

Rensselaer receives grant to integrate data sets from diverse, focused studies into a larger body of knowledge from the Bill & Melinda Gates Foundation

[ShareThis](#) [Facebook](#) [Tweet](#) [LinkedIn](#) [Pinterest](#) [Email](#)



Rensselaer Polytechnic Institute has received a grant from the Bill & Melinda Gates Foundation for the purpose of supporting the Healthy birth, growth and development (HBGD) initiative integration of multidisciplinary data to understand more fully the effects of risk factors on growth outcomes and to develop effective solutions

BILL & MELINDA
GATES foundation



Rensselaer

why not change the world? ®

“By using advanced analytical, visualization, modeling, and semantic web informatics methodologies to extract information from multiple data sources, Rensselaer and HBGD researchers will assess causal relationships and quantify risk factors in order to develop novel hypotheses and targeted approaches to impact the health of children,”

“We are extremely pleased to receive this award from the Bill & Melinda Gates Foundation to address a pressing worldwide challenge. Rensselaer is in a unique position to collaboratively design best practice ontologies and refine them as needed by virtue of the expertise of inventors, data scientists, and researchers here who are experienced at using semantic web methodologies in numerous interdisciplinary science settings.” – RPI President Shirley Ann Jackson

<http://news.rpi.edu/content/2015/08/03/rensselaer-launches-initiative-healthy-birth-growth-and-development-knowledge>

Recommended Reading

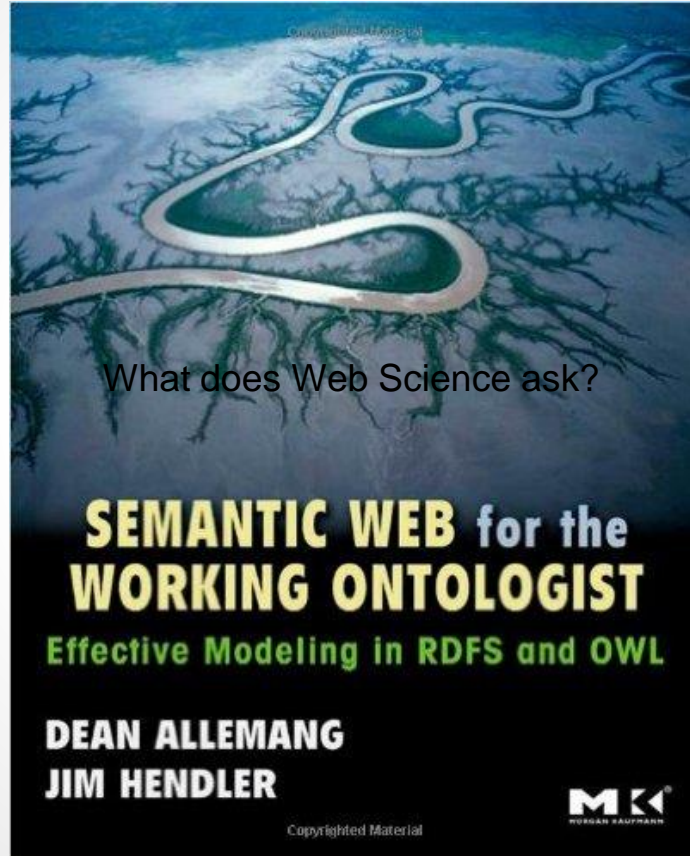

Acknowledgement

Many of the slides for this presentation provided by:

John S. Erickson, Ph.D.
Director of Operations, The Rensselaer IDEA
Deputy Director, Web Science Research Center (RPI)
<<http://tw.rpi.edu>> erickj4@rpi.edu

Many Thanks John!

For Originals see: <https://docs.google.com/presentation/d/1PdUompa-WqCBz4E2PnLQ2sul4HUsMLVlvVEzv8WWyl8/edit#slide=id.p>

Thanks for Listening!

